



# **Commercial Series CM Radios**

Controlhead  
Service Information

## **Computer Software Copyrights**

The Motorola products described in this manual may include copyrighted Motorola computer programs stored in semiconductor memories or other media. Laws in the United States and other countries preserve for Motorola certain exclusive rights for copyrighted computer programs, including the exclusive right to copy or reproduce in any form, the copyrighted computer program. Accordingly, any copyrighted Motorola computer programs contained in the Motorola products described in this manual may not be copied or reproduced in any manner without the express written permission of Motorola. Furthermore, the purchase of Motorola products shall not be deemed to grant, either directly or by implication, estoppel or otherwise, any license under the copyrights, patents or patent applications of Motorola, except for the normal non-exclusive royalty-free license to use that arises by operation of law in the sale of a product.

---

# Table of Contents

## Chapter 1 MODEL OVERVIEW

1.0 CM140/CM340 Models .....	1-1
2.0 CM160/CM360 Models .....	1-1

## Chapter 2 THEORY OF OPERATION

1.0 Introduction .....	2-1
2.0 Controlhead Model for CM140 and CM340 .....	2-1
2.1 Power Supplies.....	2-1
2.2 SPI Interface.....	2-1
2.3 Keypad Keys .....	2-1
2.4 Status LEDs and Backlight Circuit.....	2-1
2.5 Microphone Connector Signals .....	2-1
2.6 Speaker .....	2-3
2.7 Electrostatic Transient Protection .....	2-3
3.0 Controlhead Model for CM160 and CM360 .....	2-4
3.1 Power Supplies.....	2-4
3.2 SPI Interface.....	2-4
3.3 Keypad Keys .....	2-5
3.4 LCD Driver.....	2-5
3.5 Status LEDs and Backlight Circuit.....	2-5
3.6 Microphone Connector Signals .....	2-5
3.7 Speaker .....	2-6
3.8 Electrostatic Transient Protection .....	2-6

## Chapter 3 TROUBLESHOOTING CHARTS

1.0 Troubleshooting Chart for Controlhead CM140/340 .....	3-1
1.1 Controlhead Failure .....	3-1
1.2 Button/Tones Select Error (1 of 2).....	3-2
1.3 Button/Tones Select Error (2 of 2).....	3-3
2.0 Troubleshooting Chart for Controlhead CM160/360 .....	3-4
2.1 Controlhead Failure .....	3-4
2.2 Button/Tones Select Error .....	3-5
2.3 Button/Tones Select Error .....	3-6

---

## **Chapter 4    CONTROLHEAD PCB/SCHEMATICS/PARTS LISTS**

1.0	Allocation of Schematics and Circuit Boards .....	4-1
2.0	Controlhead CM140/340 - PCB 8488998U01 Schematics .....	4-3
2.1	Controlhead PCB 8488998U01 - Parts List.....	4-5
3.0	Controlhead CM160/360 - PCB 8489714U01 Schematics .....	4-6
3.1	Controlhead PCB 8489714U01 - Parts List .....	4-8

## OVERVIEW

### 1.0 CM140/CM340 Models

The Controlhead contains the internal speaker, the on/off/volume knob, the microphone connector, several buttons to operate the radio, three indicator Light Emitting Diodes (LED) to inform the user about the radio status, and a single character 7-segment display for numeric information e.g. channel number.

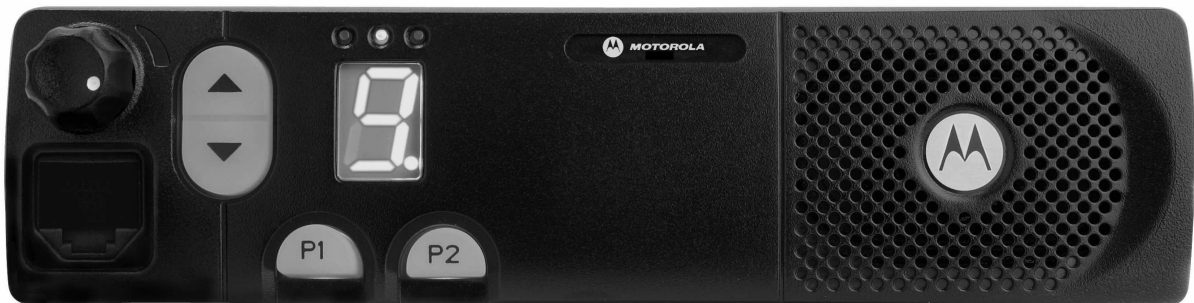

### 2.0 CM160/CM360 Models

The Controlhead contains the internal speaker, the on/off/volume knob, the microphone connector, several buttons to operate the radio, three indicator Light Emitting Diodes (LED) to inform the user about the radio status, and an 8 character Liquid Crystal Display (LCD) for alpha - numerical information e.g. channel number or call address name.





# Chapter 2

## THEORY OF OPERATION

### 1.0 Introduction

This Chapter provides a detailed theory of operation for the Controlhead circuits. For details of the trouble shooting refer to the related chapter in this section.

### 2.0 Controlhead Model for CM140 and CM340

The controlhead contains the internal speaker, the on/off/volume knob, the microphone connector, several buttons to operate the radio and three indicator Light Emitting Diodes (LED) to inform the user about the radio status and a 7-segment display for numeric information.

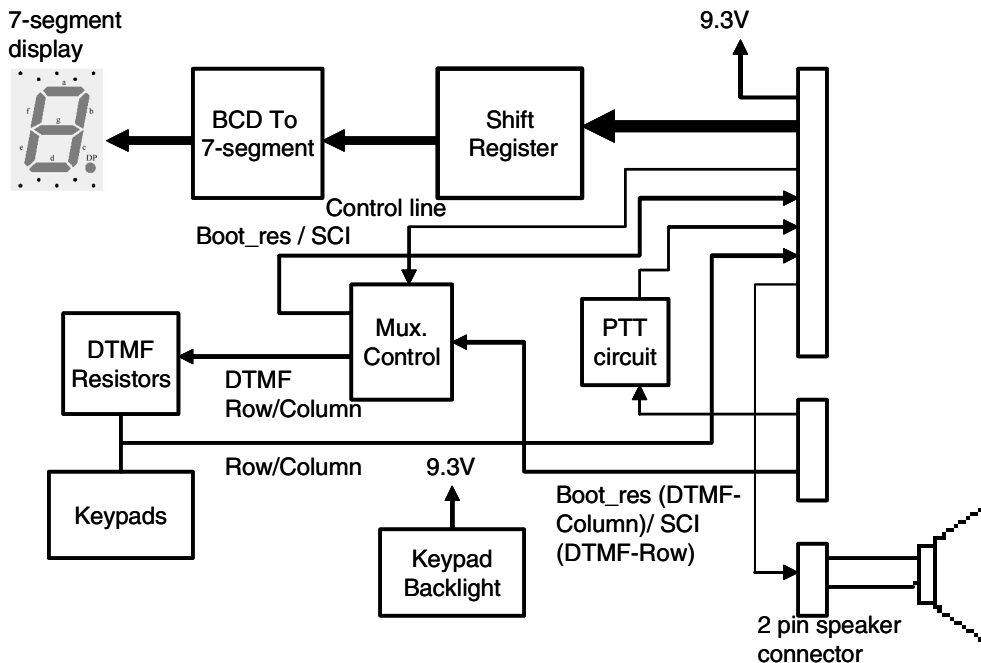

### 2.1 Power Supplies

The power supply to the control head is taken from the host radio's 9.3V via connector J803-9, The 9.3V is used for the LEDs and back light, the 5V is used for the LCD driver and level shifter. The stabilized 3V is used for the other parts.

### 2.2 SPI Interface

The host radio (master) communicates with the control head through its SPI bus. Three lines are connected to the shift register (U801): SPI clock (J803-17), SPI MOSI (J803-16) and shift register chip select (J803-15).

When the host radio needs to send data to the shift register, the radio asserts the shift register chip select and the data is loaded to the shift register. For example, the host radio sends data to change display channel or change LED status.

## 2.3 Keypad Keys

The control head keypad is a four-key design. All keys are configured as two analog lines read by  $\mu$ P. The voltage on the analog lines varies between 0V and 3.3 V depending on which key is pressed. If no key is pressed, the voltage at both lines is 3.3V. The key configuration can be thought of as a matrix where the two lines represent one row and one column. Each line is connected to a resistive divider powered by 3.3V. If a button is pressed, it will connect one specific resistor of each divider line to ground level and thereby reduce the voltages on the analog lines. The voltages of the lines are A/D converted inside the  $\mu$ P (ports PE 6 - 7) and specify the pressed button. To determine which key is pressed, the voltage of both lines must be considered.

The same analog lines also support a keypad microphone. A microphone key press is processed in the same manner like a control head key press.

## 2.4 Status LED's and Back Light Circuit

All indicator LEDs (red, yellow, and green) are driven by current sources. To change the LED status the host radio sends a data message to the control head shift register via the SPI bus. The control head shift register determines the LED status from the received data and switches the LEDs on or off via Q5-Q7.

The back light for the keypad is always on. The back light current for the keypad is drawn from the 9.3 V source and controlled by two current sources. The LED current is determined by the resistor at the emitter of the respective current source transistor.

## 2.5 Microphone Connector Signals

The MIC\_PTT line (J802-3) is grounded when the PTT button on the microphone is pressed. When released, this line is pulled to 9.3V by R805. Two transistor stages (Q802, Q801 and associated parts) are used to level shift between 9.3V and 3.3V required for the uP while keeping the same sense (active low for PTT pressed).

Two of the mic socket lines (J802-2,7) have dual functions depending on the type of microphone or SCI lead connected. An electronic switch (U803) is used to switch these two lines between mic keypad operation or SCI operation. The switch (mux) is controlled by the uP through J803-20 with level shifting (and inversion) provided by transistor Q812. When MUX\_CTRL (J803-20) is low the electronic switch is in the mic keypad mode. The mic socket (J802) pin 2 is connected to the keypad row line that goes to J803-13 and pin 7 is connected to the keypad column line that goes to J803-12. When MUX\_CTRL (J803-20) is high the electronic switch is in the SCI mode. The mic socket (J802) pin 2) is connected to the SCI line that goes to J803-4 and pin 7 is connected to the BOOT\_RES line that goes to J803-11.

The HOOK line (J802-6) is used to inform the uP which type of microphone or SCI lead is connected to the microphone socket. The voltage of the HOOK line is monitored by the uP (port PE0, MIC\_SENSE) through a resistor divider on the main board. When the HOOK line is grounded (on hook condition) or floating (2.8V nominal), the uP sets the mux (U803) for keypad operation to allow the use of microphones with a keypad. When the HOOK line is connected to 9.3V, the uP sets the mux for SCI operation. This mode is also used to select low cost mic operation where the gain of the microphone path is increased (on the main board) to compensate for not having a pre-amp in the low cost mic.



---

If the BOOT\_RES (J802-7) line is connected to >5V (e.g. 9.3V) at turn-on, the uP will start in boot mode instead of normal operation. This mode is used to programme new firmware into the FLASH memory (U404 mainboard).

## 2.6 Speaker

The controlhead contains a speaker for the receiver audio. The receiver audio signal from the differential audio output of the audio amplifier located on the radio's controller is fed via connector J803-1, 2 to the speaker connector P801 pin 1 and pin 2. The speaker is connected to the speaker connector P801. The controlhead speaker can be disconnected if an external speaker, connected on the accessory connector, is used.

## 2.7 Electrostatic Transient Protection

Electrostatic transient protection is provided for the sensitive components in the controlhead by diodes VR801, VR802, VR803 and VR804. The diodes limit any transient voltages to tolerable levels. The associated capacitors provide Radio Frequency Interference (RFI) protection.

### 3.0 Controlhead Model for CM160 and CM360

The controlhead contains the internal speaker, the on/off/volume knob, the microphone connector, several buttons to operate the radio, three indicator Light Emitting Diodes (LED) to inform the user about the radio status, and an 8 character Liquid Crystal Display (LCD) for alpha - numerical information e.g. channel number or call address name.

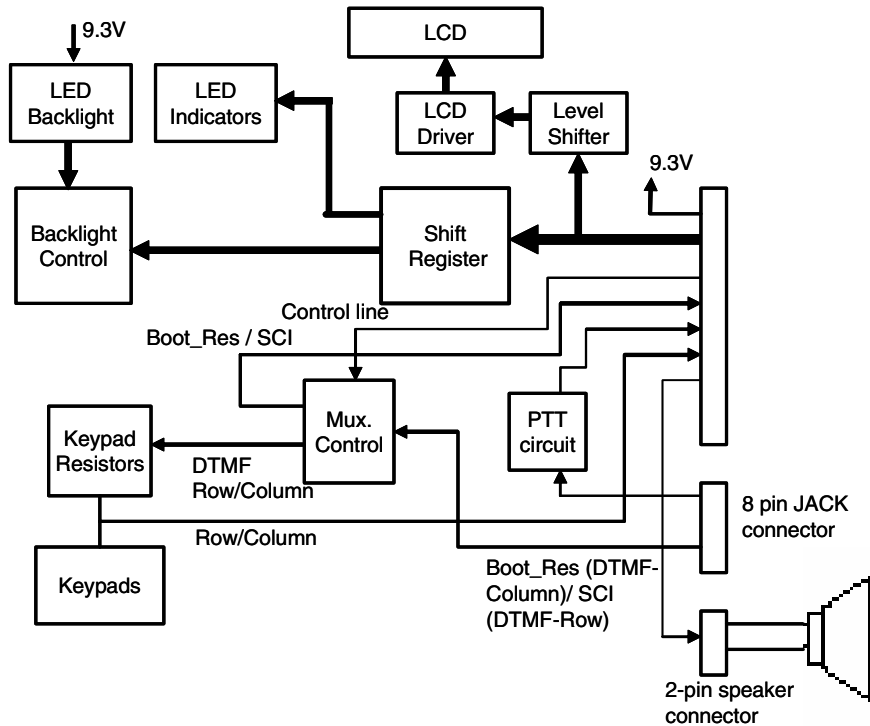

#### 3.1 Power Supplies

The power supply to the control head is taken from the host radio's 9.3V via connector J103-9. The 9.3V is used for the LEDs and back light, the 5V is used for the LCD driver (U3) and level shifter (U4). The stabilized 3V is used for the other parts.

#### 3.2 SPI Interface

The host radio (master) communicates with the control head through its SPI bus. Three lines are connected to the shift register (U8): SPI clock (J103-17), SPI MOSI (J103-16), shift register chip select (J103-15) and LCD driver chip select (J103-18).

When the host radio needs to send data to the shift register, the radio asserts the shift register chip select and the data is loaded to the shift register. For example, the host radio sends data to change display channel or change LED status.

### 3.3 Keypad Keys

The control head keypad is a four-key design. All keys are configured as two analog lines read by  $\mu$ P. The voltage on the analog lines varies between 0V and 3.3 V depending on which key is pressed. If no key is pressed, the voltage at both lines is 3.3V. The key configuration can be thought of as a matrix where the two lines represent one row and one column. Each line is connected to a resistive divider powered by 3.3V. If a button is pressed, it will connect one specific resistor of each divider line to ground level and thereby reduce the voltages on the analog lines. The voltages of the lines are A/D converted inside the  $\mu$ P (ports PE 6 - 7) and specify the pressed button. To determine which key is pressed, the voltage of both lines must be considered.

The same analog lines also support a keypad microphone. A microphone key press is processed in the same manner like a control head key press.

### 3.4 LCD Driver

The LCD (36 x 4 segments) is controlled by U3. It has an on-board clock controlled by R28 (typically 20kHz measured on pin 2). U3 is operated from the 5V supply and is controlled over the SPI bus (SPI\_CLK J103-17, SPI\_MOSI J103-16, LCD chip select J103-18). Chip select is active low. U2 is used to provide level shifting between the 3.3V logic from the  $\mu$ P and the 5V required by U3.

### 3.5 Status LED's and Back Light Circuit

All indicator LEDs (red, yellow, and green) are driven by current sources. To change the LED status the host radio sends a data message to the control head shift register via the SPI bus. The control head shift register determines the LED status from the received data and switches the LEDs on or off via Q8-Q10.

Backlighting for the LCD and keys is provided by a matrix of 21 LEDs arranged in 7 columns of 3 rows. The LEDs are driven from a constant current circuit (Q12, U1 and associated parts). There are 4 levels of backlight: off, low, medium and high, which are controlled by two outputs (pins 15, 1) from the shift register (U8). The current is controlled by transistor Q12. The op amp U1 monitors the current by measuring the voltage drop across R26, R27 and adjusting the bias of Q12 to achieve the required level as set by the combined shift register outputs. When in the off state, Q11 is also turned on to clamp the base of Q12 so as to force it off. This ensures that the LEDs are fully off. Q11 is controlled by pin 3 of the shift register U8.

### 3.6 Microphone Connector Signals

The MIC\_PTT line (J102-3) is grounded when the PTT button on the microphone is pressed. When released, this line is pulled to 9.3V by R33. Two transistor stages (Q14, Q13 and associated parts) are used to level shift between 9.3V and 3.3V required for the  $\mu$ P while keeping the same sense (active low for PTT pressed).

Two of the mic socket lines (J102-2, 7) have dual functions depending on which type of microphone or SCI lead that is connected. An electronic switch (U41) is used to switch these two lines between mic keypad operation or SCI operation. The switch (mux) is controlled by the  $\mu$ P through J103-20 with level shifting (and inversion) provided by transistor Q41. When MUX\_CTRL (103-20) is low the electronic switch is in the mic keypad mode. The mic socket (J102) pin 2 is connected to the keypad row line that goes to J103-13 and pin 7 is connected to the keypad column line that goes to 103-12. When MUX\_CTRL (103-20) is high the electronic switch is in the SCI mode. The mic socket (J102) pin 2) is connected to the SCI line that goes to J103-4 and pin 7 is connected to the BOOT\_RES line that goes to J103-11.

The HOOK line (J102-6) is used to inform the uP which type of microphone or SCI lead is connected to the microphone socket. The voltage of the HOOK line is monitored by the uP (port PE0, MIC\_SENSE) through a resistor divider on the main board. When the HOOK line is grounded (on hook condition) or floating (2.8V nominal), the uP sets the mux (U8) for keypad operation to allow the use of microphones with a keypad. When the HOOK line is connected to 9.3V, the uP sets the mux for SCI operation. This mode is also used to select low cost mic operation where the gain of the microphone path is increased (on the main board) to compensate for not having a pre-amp in the low cost mic.

If the BOOT\_RES (J102-7) line is connected to >5V (e.g. 9.3V) at turn-on then the uP will start in boot mode instead of normal operation. This mode is used to programme new firmware into the FLASH memory (U404 mainboard).

### **3.7 Speaker**

The controlhead contains a speaker for the receiver audio. The receiver audio signal from the differential audio output of the audio amplifier located on the radio's controller is fed via connector J103-1, 2 to the speaker connector P101 pin 1 and pin 2. The speaker is connected to the speaker connector P101. The controlhead speaker can be disconnected if an external speaker, connected on the accessory connector, is used.

### **3.8 Electrostatic Transient Protection**

Electrostatic transient protection is provided for the sensitive components in the controlhead by diodes VR1 - VR4. The diodes limit any transient voltages to tolerable levels. The associated capacitors provide Radio Frequency Interference (RFI) protection.

## TROUBLESHOOTING CHARTS

### 1.0 Controlhead CM140/CM340 Troubleshooting Chart

#### 1.1 Control Head Failure

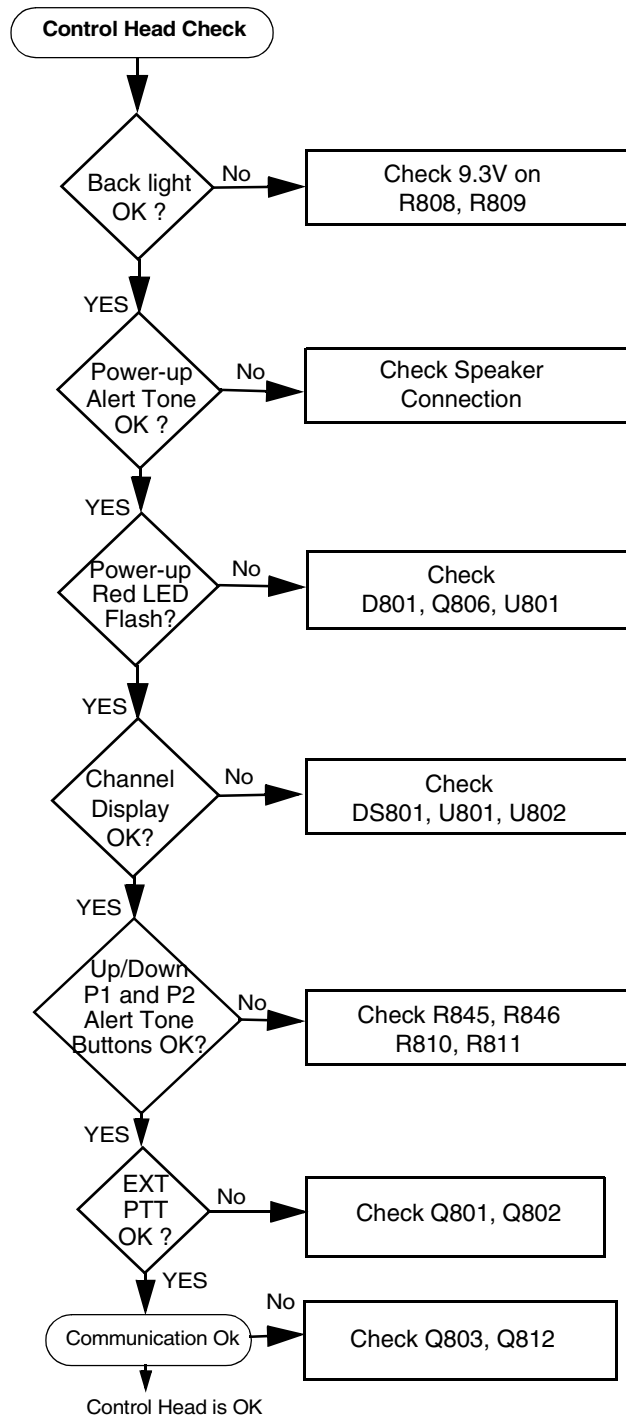

## 1.2 Button/Tones Select Error (Page 1 of 2)

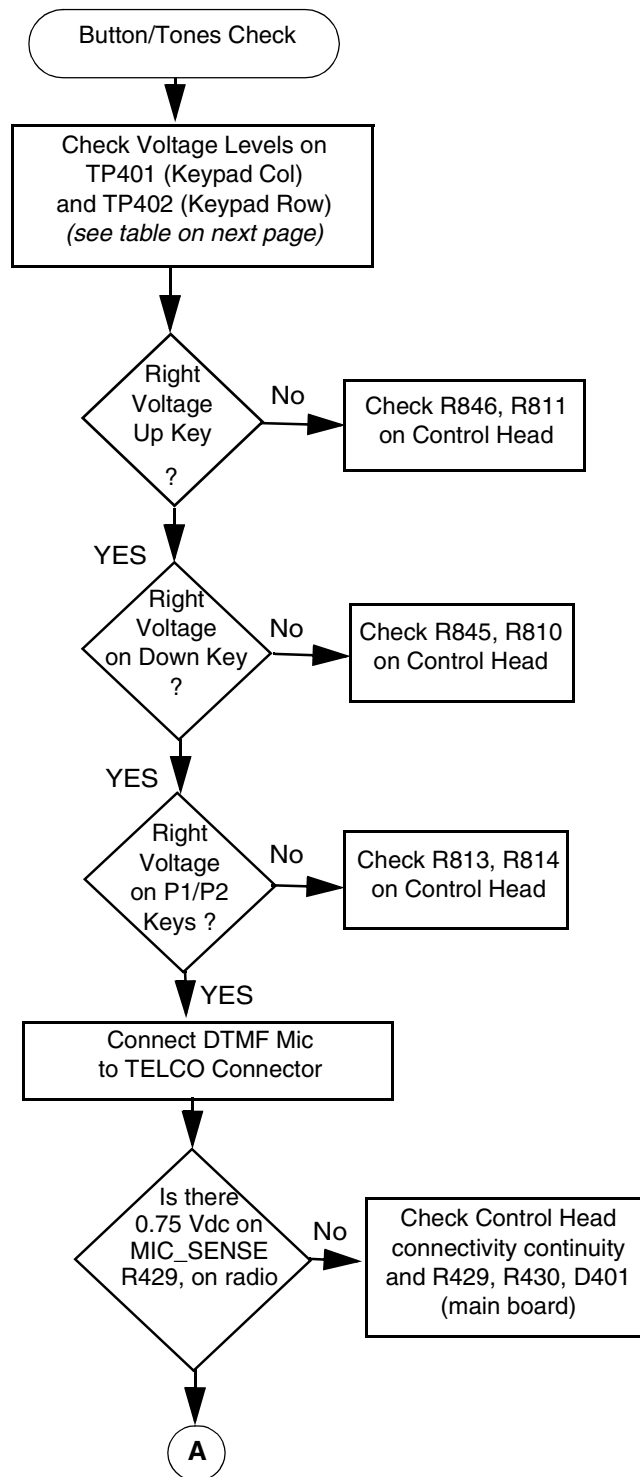

### 1.3 Button/Tones Select Error (Page 2 of 2)

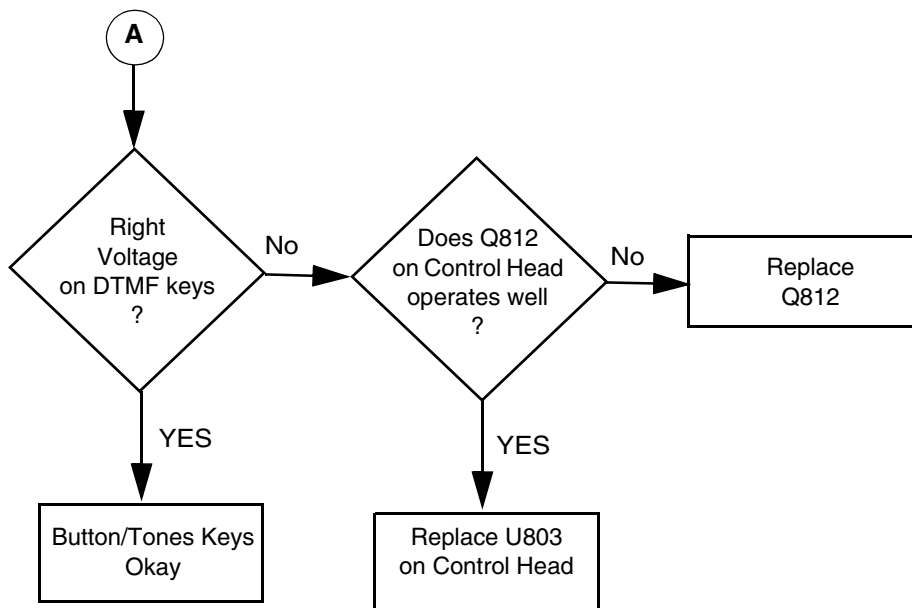

	Key_Col Voltage (TP401)	Key_Column Voltage TP401					
		0.008 V	0.675 V	1.346 V	1.997 V	2.650 V	3.300 V
<b>Key_Row Voltage TP402</b>	0.008 V						Up
	0.675 V			1	2	3	
	1.346 V		4	5	6	7	
	1.997 V		8	9	0	*	
	2.650 V		#	C	B	A	
	3.300 V	<b>Down</b>	<b>Left Key P1</b>	<b>Right Key P2</b>			<b>Idle</b>

## 2.0 Controlhead CM160/CM360 Troubleshooting Chart

### 2.1 Control Head Failure

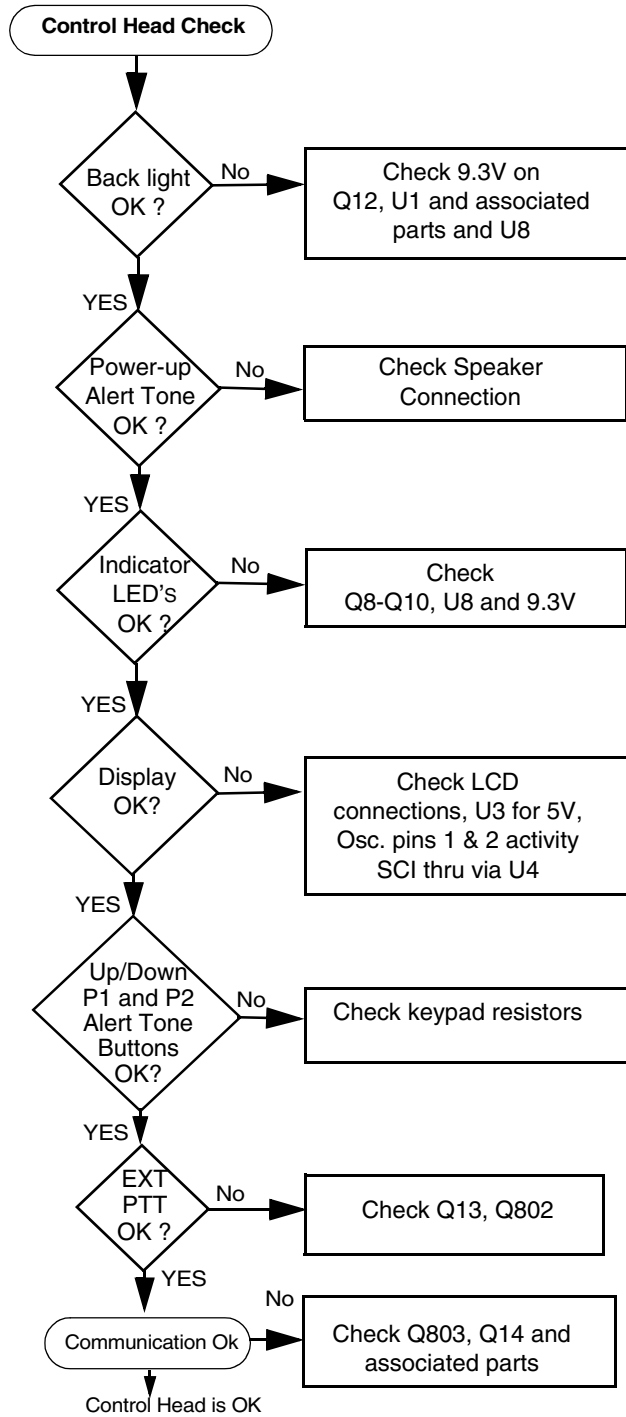



## 2.2 Button/Tones Select Error (Page 1 of 2)

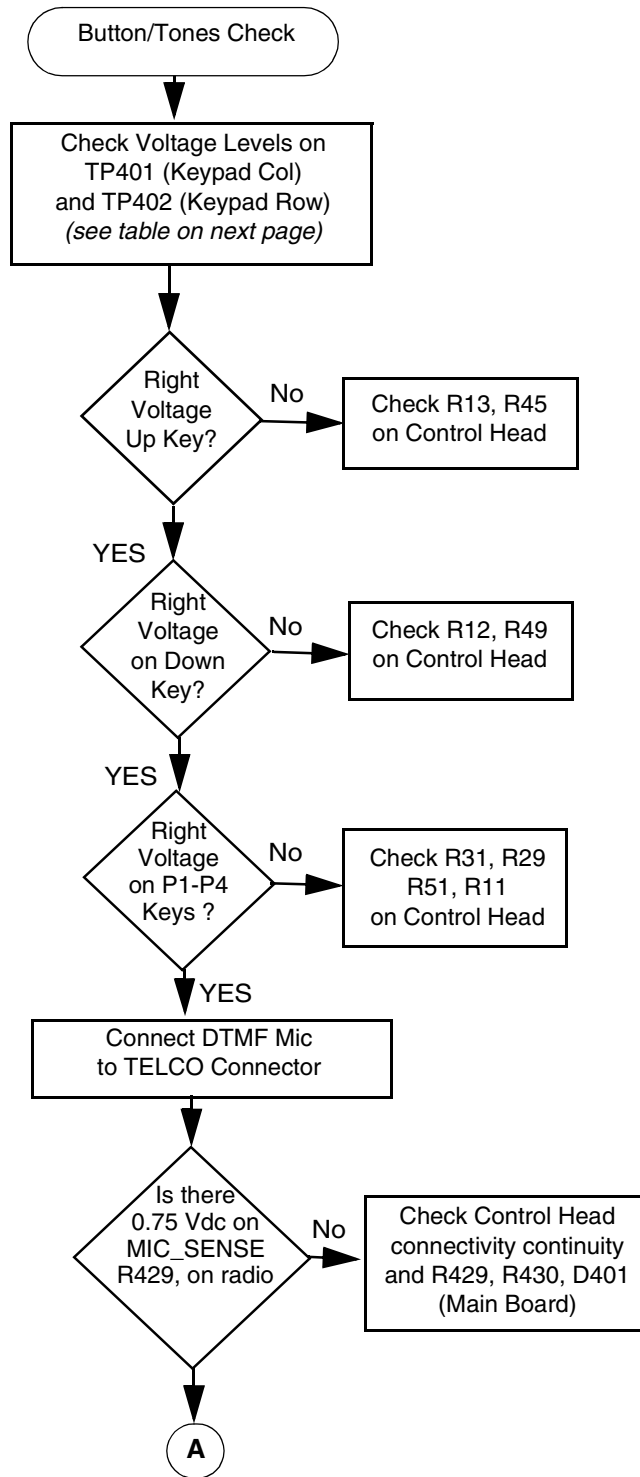

### 2.3 Button/Tones Select Error (Page 2 of 2)

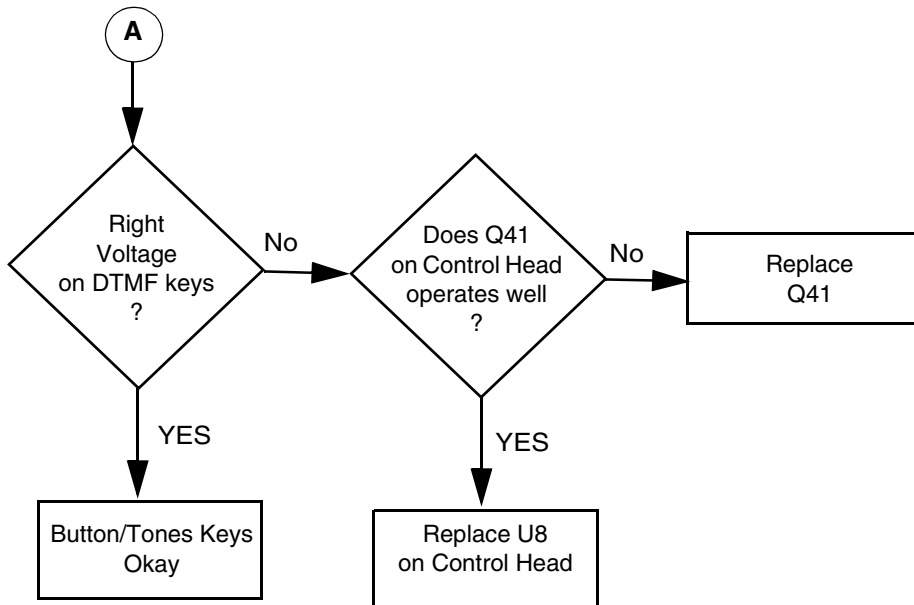

	Key_Col Voltage (TP401)	Key_Column Voltage TP401					
		0.008 V	0.675 V	1.346 V	1.997 V	2.650 V	3.300 V
Key_Row Voltage TP402	0.008 V						Up
	0.675 V			1	2	3	
	1.346 V		4	5	6	7	
	1.997 V		8	9	0	*	
	2.650 V		#	C	B	A	
	3.300 V	Down	Left Key P1	Right Key P2	P3	P4	Idle

## CONTROLHEAD PCB / SCHEMATICS / PARTS LISTS

### 1.0 Allocation of Schematics and Circuit Boards

Table 4-1 Controlhead Diagrams and Parts Lists

<b>PCB :</b> Controlhead CM140/CM340 <b>8488998U01</b> Main Board Top Side <b>8488998U01</b> Main Board Bottom Side	Page 4-3 Page 4-3
<b>SCHEMATICS</b> Sheet 1 of 1	Page 4-4
<b>Parts List</b> <b>8488998U01</b>	Page 4-5

Table 4-2 Controlhead Diagrams and Parts Lists

<b>PCB :</b> Controlhead CM160/CM360 <b>8489714U01</b> Main Board Top Side <b>8489714U01</b> Main Board Bottom Side	Page 4-6 Page 4-6
<b>SCHEMATICS</b> Sheet 1 of 1	Page 4-7
<b>Parts List</b> <b>8489714U01</b>	Page 4-8

**THIS PAGE INTENTIONALLY LEFT BLANK**

## 2.0 Controlhead CM140/CM340 - PCB 8488998U01 / Schematics

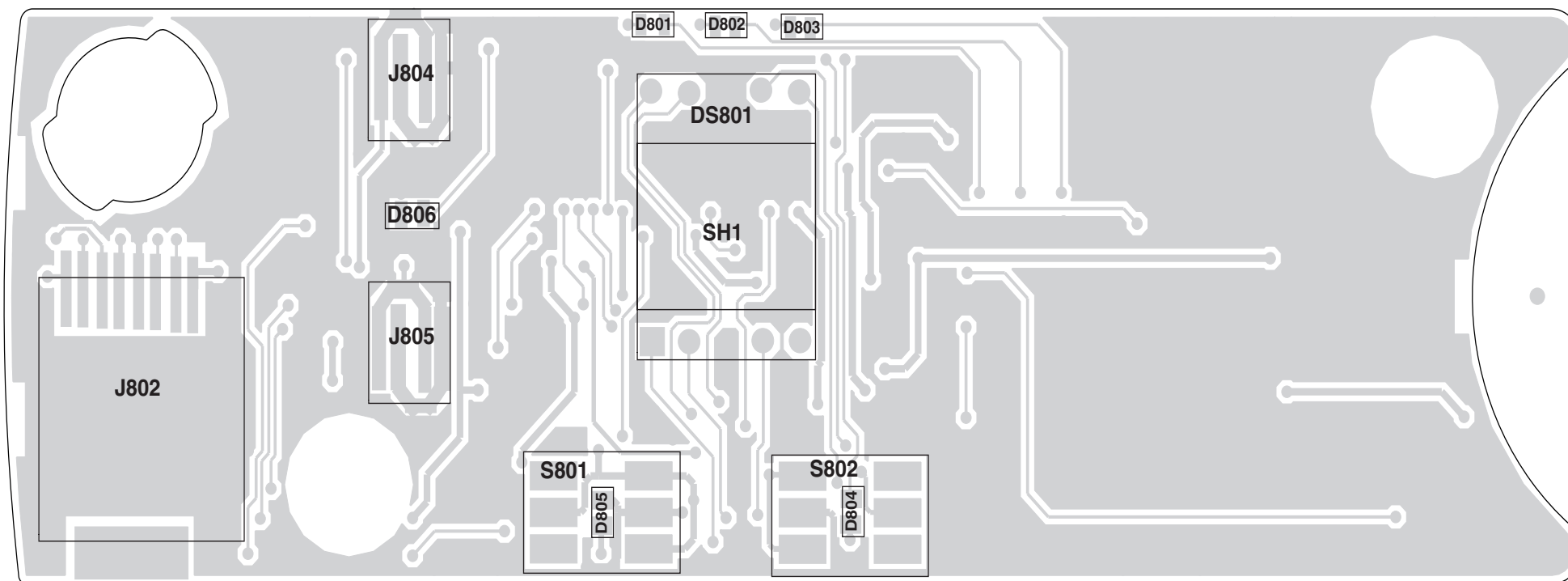

SHOWN FROM SIDE 1

Top Side

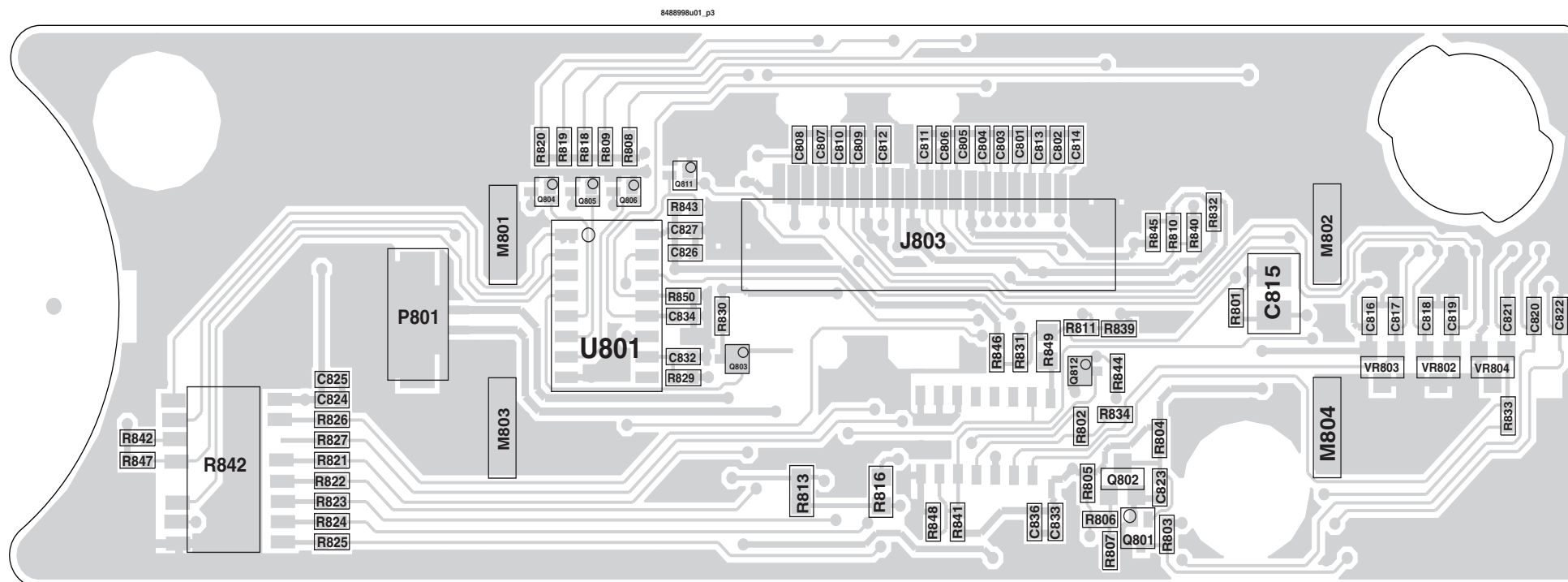

SHOWN FROM SIDE 2

Bottom Side

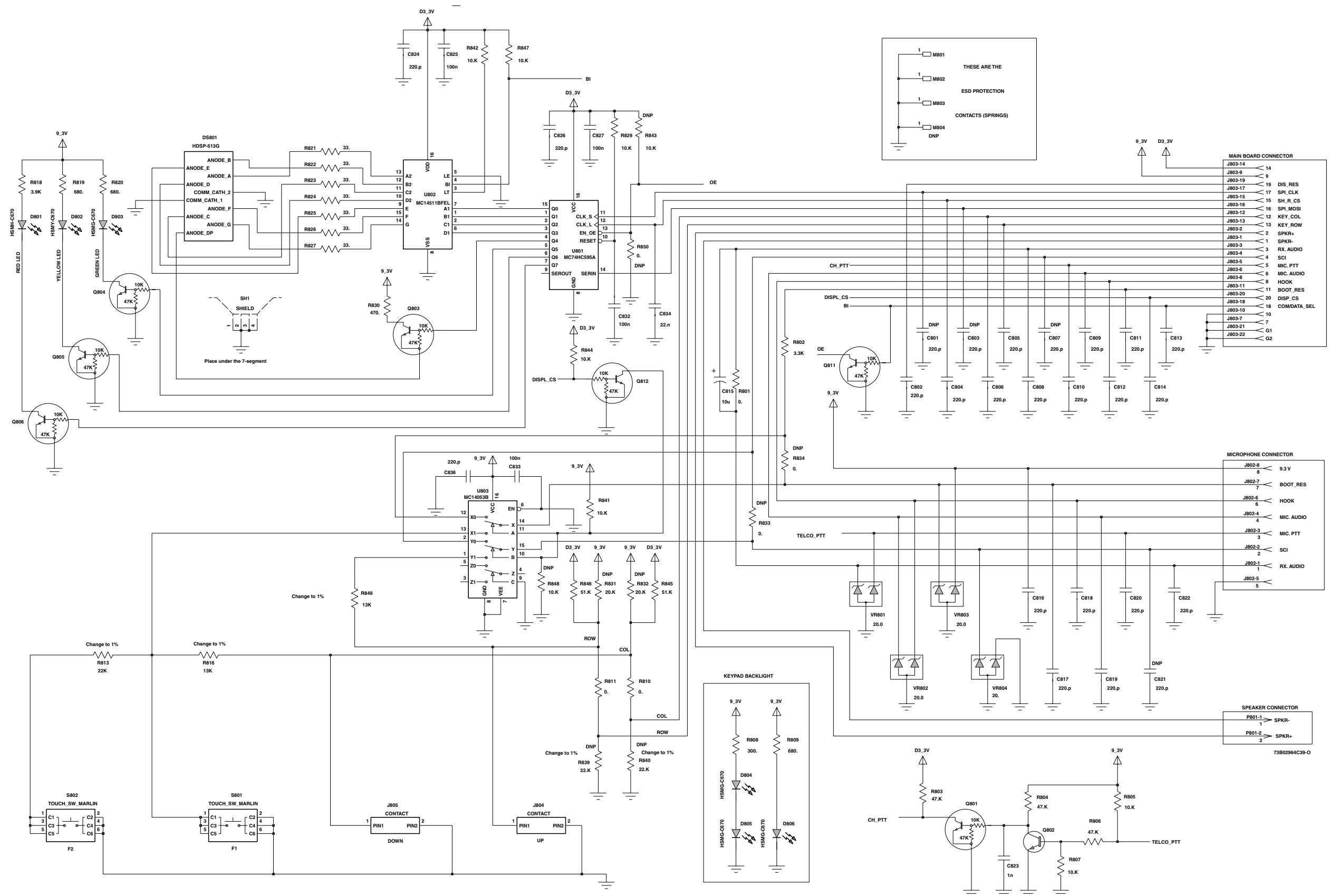

Controlhead CM140/CM340 Schematic

**2.1 Controlhead PCB 8488998U01 Parts List**

Circuit Ref	Motorola Part No	Description
C802	2113740F59	CAP CHIP REEL CL13
C804	2113740F59	CAP CHIP REEL CL13
C805	2113740F39	CAP CHIP REEL CL1+/-30 33
C806	2113740F39	CAP CHIP REEL CL1+/-30 33
C808	2113740F59	CAP CHIP REEL CL13
C809	2113740F39	CAP CHIP REEL CL1+/-30 33
C810	2113740F39	CAP CHIP REEL CL1+/-30 33
C811	2113740F59	CAP CHIP REEL CL13
C812	2113740F39	CAP CHIP REEL CL1+/-30 33
C813	2113740F59	CAP CHIP REEL CL13
C814	2113740F59	CAP CHIP REEL CL13
C816	2113740F39	CAP CHIP REEL CL1+/-30 33
C817	2113740F39	CAP CHIP REEL CL1+/-30 33
C818	2113740F39	CAP CHIP REEL CL1+/-30 33
C819	2113740F39	CAP CHIP REEL CL1+/-30 33
C820	2113740F39	CAP CHIP REEL CL1+/-30 33
C821	2113740F29	CAP CHIP REEL CL1+/-30 12
C822	2113740F39	CAP CHIP REEL CL1+/-30 33
C823	2113743K15	CER CHIP CAP .100uF
C824	2113740F59	CAP CHIP REEL CL13
C825	2113743K15	CER CHIP CAP .100uF
C826	2113740F59	CAP CHIP REEL CL13
C827	2113743K15	CER CHIP CAP .100uF
C832	2113743K15	CER CHIP CAP .100uF
C833	2113743K15	CER CHIP CAP .100uF
C834	2113743E07	CER CHIP CAP .022uF
C836	2113740F59	CAP CHIP REEL CL13
D801	4805729G74	LED SMT RED HP
D802	4805729G73	LED SMT YEL HP
D803	4805729G75	LED SMT GREEN HP
D804	4805729G75	LED SMT GREEN HP
D805	4805729G75	LED SMT GREEN HP
D806	4805729G75	LED SMT GREEN HP
DS801	5180353L02	7-SEGMENT DISPLAY
J802	0908353Y02	MODULAR 8-PIN STR

Circuit Ref	Motorola Part No	Description
J803	0989241U02	FLEX 20-PIN 1mmTOP NON
M801	7588823L03	PAD GROUND LCD
M802	7588823L03	PAD GROUND LCD
M803	7588823L03	PAD GROUND LCD
M804	7588823L03	PAD GROUND LCD
P801	2809926G01	CONN 1.25MM 2PIN SURMT
Q801	4809940E02	TSTR NPN DIG DTC114YE
Q802	4813824A10	TSTR NPN 40V .2A GEN P
Q803	4809940E02	TSTR NPN DIG DTC114YE
Q804	4809940E02	TSTR NPN DIG DTC114YE
Q805	4809940E02	TSTR NPN DIG DTC114YE
Q806	4809940E02	TSTR NPN DIG DTC114YE
Q811	4809940E02	TSTR NPN DIG DTC114YE
Q812	4809940E02	TSTR NPN DIG DTC114YE
R801	0662057A01	CHIP RES 10 OHMS 5%
R802	0662057A61	CHIP RES 330 OHMS 5%
R803	0662057A89	CHIP RES 47K OHMS 5%
R804	0662057A89	CHIP RES 47K OHMS 5%
R805	0662057A73	CHIP RES 10K OHMS 5%
R806	0662057A89	CHIP RES 47K OHMS 5%
R807	0662057A73	CHIP RES 10K OHMS 5%
R808	0662057A36	CHIP RES 300 OHMS 5%
R809	0662057A45	CHIP RES 680 OHMS 5%
R810	0662057B47	CHIP RES 0 OHMS +0.5
R811	0662057B47	CHIP RES 0 OHMS +0.5
R813	0662057D08	CHIP RES 22K OHMS 5%
R816	0662057D03	CHIP RES 13K OHMS 5%
R818	0662057A63	CHIP RES 3900 OHMS 5%
R819	0662057A45	CHIP RES 680 OHMS 5%
R820	0662057A45	CHIP RES 680 OHMS 5%
R821	0662057A13	CHIP RES 33 OHMS 5%
R822	0662057A13	CHIP RES 33 OHMS 5%
R823	0662057A13	CHIP RES 33 OHMS 5%
R824	0662057A13	CHIP RES 33 OHMS 5%
R825	0662057A13	CHIP RES 33 OHMS 5%
R826	0662057A13	CHIP RES 33 OHMS 5%
R827	0662057A13	CHIP RES 33 OHMS 5%
R829	0662057A73	CHIP RES 10K OHMS 5%

Circuit Ref	Motorola Part No	Description
R830	0662057A41	CHIP RES 470 OHMS 5%
R841	0662057A73	CHIP RES 10K OHMS 5%
R842	0662057A73	CHIP RES 10K OHMS 5%
R843	0662057A73	CHIP RES 10K OHMS 5%
R844	0662057A73	CHIP RES 10K OHMS 5%
R845	0662057A90	CHIP RES 51K OHMS 5%
R846	0662057A90	CHIP RES 51K OHMS 5%
R849	0662057D03	CHIP RES 13K OHMS 5%

### 3.0 Controlhead CM160/CM360 - PCB 8489714U01 / Schematics

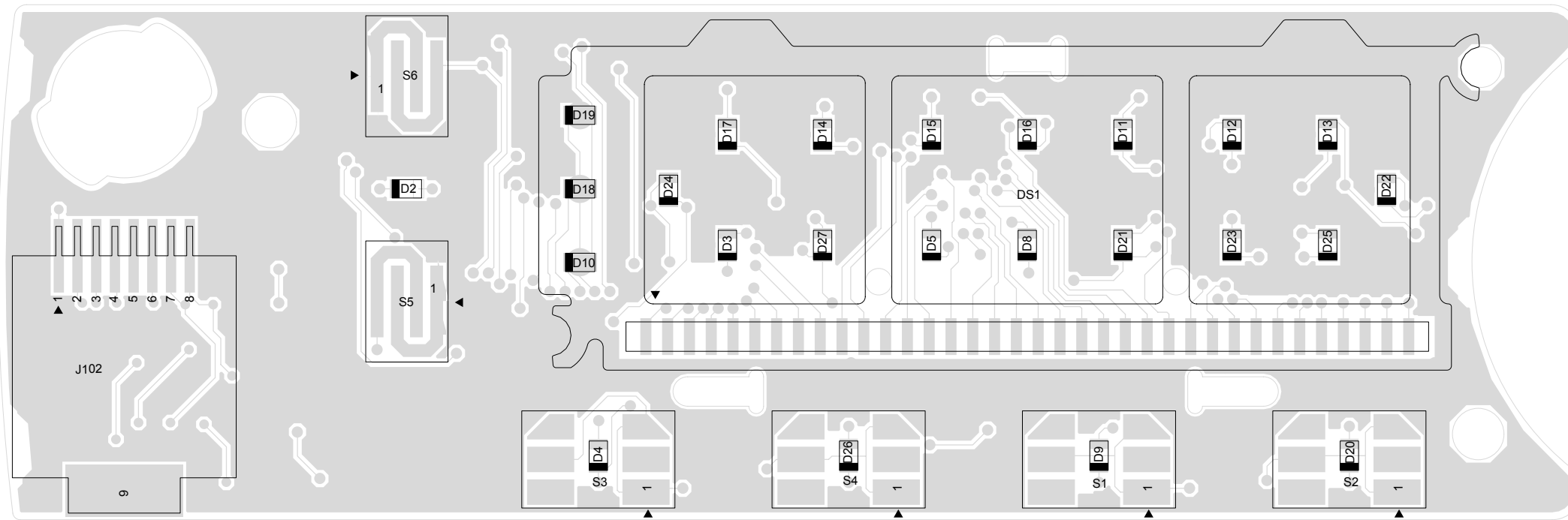

Top Side

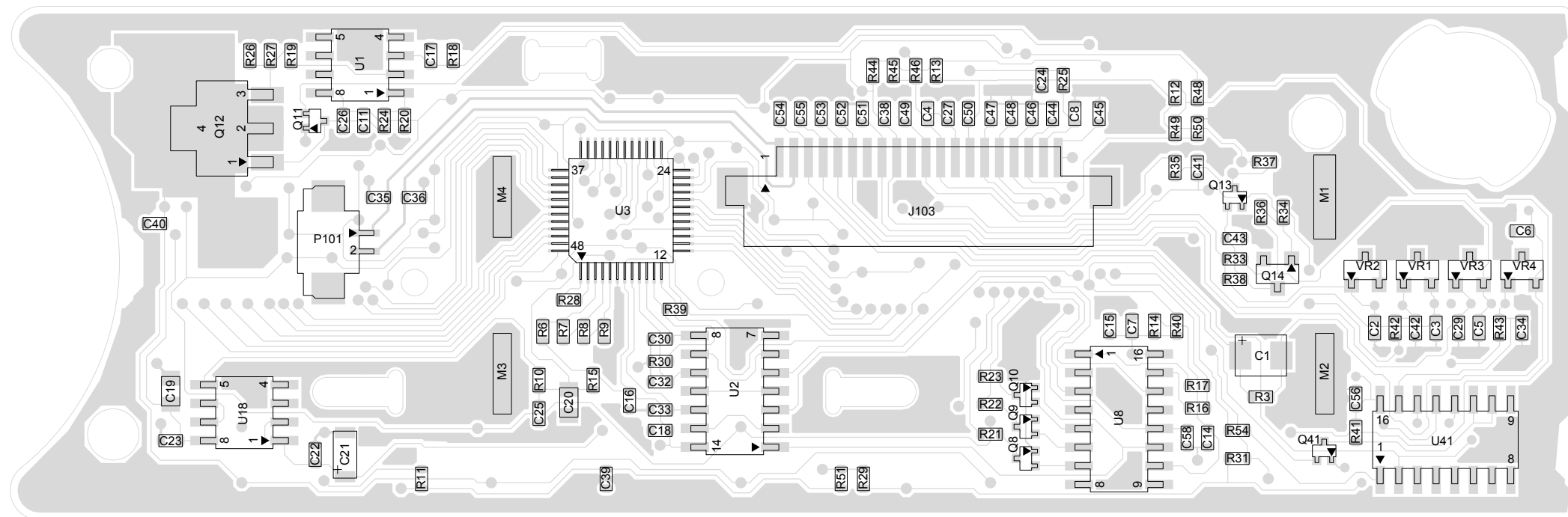

Bottom Side

**Controlhead CM160/CM360 PCB  
8489714U01**



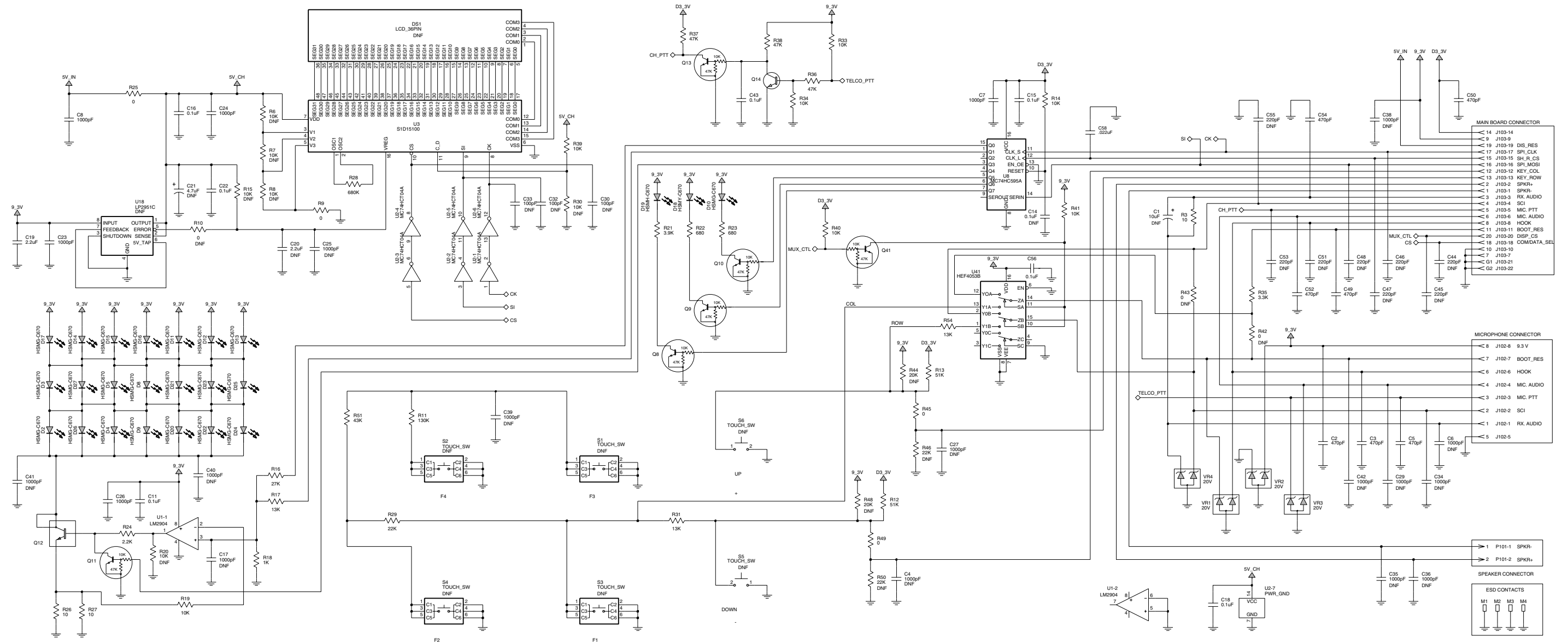

Controlhead CM160/CM360 Schematic

**3.1 Controlhead PCB 8489714U01 Parts List**

Circuit Ref	Motorola Part No	Description
C1	NOTPLACED	CAP, 10uF
C2	2113740F67	CAP, 470pF
C3	2113740F67	CAP, 470pF
C4	2113740F12	CAP CHIP REEL CL1 +/-30 12
C5	2113740F67	CAP, 470pF
C6	2113740F12	CAP CHIP REEL CL1 +/-30 12
C7	2113741F25	CAP, 1000pF
C8	2113741F25	CAP, 1000pF
C11	2113743K15	CAP, 0.1uF
C14	NOTPLACED	CAP, 0.1uF
C15	2113743K15	CAP, 0.1uF
C16	2113743K15	CAP, 0.1uF
C17	NOTPLACED	CAP, 1000pF
C18	2113743K15	CAP, 0.1uF
C19	2113743F18	CAP, 2.2uF
C20	NOTPLACED	CAP, 2.2uF
C21	NOTPLACED	CAPP, 4.7uF
C22	2113743K15	CAP, 0.1uF
C23	2113741F25	CAP, 1000pF
C24	2113741F25	CAP, 1000pF
C25	NOTPLACED	CAP, 1000pF
C26	2113741F25	CAP, 1000pF
C27	2113740F12	CAP CHIP REEL CL1 +/-30 12
C29	2113740F12	CAP CHIP REEL CL1 +/-30 12
C30	NOTPLACED	CAP, 100pF
C32	NOTPLACED	CAP, 100pF
C33	NOTPLACED	CAP, 100pF
C34	2113740F12	CAP CHIP REEL CL1 +/-30 12
C35	NOTPLACED	CAP, 1000pF
C36	NOTPLACED	CAP, 1000pF
C38	NOTPLACED	CAP, 1000pF
C39	NOTPLACED	CAP, 1000pF
C40	NOTPLACED	CAP, 1000pF
C41	NOTPLACED	CAP, 1000pF
C42	2113740F12	CAP CHIP REEL CL1 +/-30 12
C43	2113743K15	CAP, 0.1uF

Circuit Ref	Motorola Part No	Description
C44	NOTPLACED	CAP, 220pF
C45	NOTPLACED	CAP, 220pF
C46	NOTPLACED	CAP, 220pF
C47	NOTPLACED	CAP, 220pF
C48	NOTPLACED	CAP, 220pF
C49	2113740F67	CAP, 470pF
C50	2113740F67	CAP, 470pF
C51	2113740F12	CAP CHIP REEL CL1 +/-30 12
C52	2113740F67	CAP, 470pF
C53	2113740F12	CAP CHIP REEL CL1 +/-30 12
C54	2113740F67	CAP, 470pF
C55	NOTPLACED	CAP, 220pF
C56	2113743K15	CAP, 0.1uF
C58	2113743E07	CAP, .022uF
D2	4805729G75	HSMG-C670
D3	4805729G75	HSMG-C670
D4	4805729G75	HSMG-C670
D5	4805729G75	HSMG-C670
D8	4805729G75	HSMG-C670
D9	4805729G75	HSMG-C670
D10	4805729G75	HSMG-C670
D11	4805729G75	HSMG-C670
D12	4805729G75	HSMG-C670
D13	4805729G75	HSMG-C670
D14	4805729G75	HSMG-C670
D15	4805729G75	HSMG-C670
D16	4805729G75	HSMG-C670
D17	4805729G75	HSMG-C670
D18	4805729G73	HSMY-C670
D19	4805729G74	HSMH-C670
D20	4805729G75	HSMG-C670
D21	4805729G75	HSMG-C670
D22	4805729G75	HSMG-C670
D23	4805729G75	HSMG-C670
D24	4805729G75	HSMG-C670
D25	4805729G75	HSMG-C670
D26	4805729G75	HSMG-C670
D27	4805729G75	HSMG-C670
DS1	NOTPLACED	LCD_36PIN

Circuit Ref	Motorola Part No	Description
J102	0908353Y02	CONN_J
J103	0989241U02	CONN_J
M1	7588823L03	CONTACT
M2	7588823L03	CONTACT
M3	7588823L03	CONTACT
M4	7588823L03	CONTACT
P101	2809926G01	CONN_P
Q8	4809940E02	DTC114YE
Q9	4809940E02	DTC114YE
Q10	4809940E02	DTC114YE
Q11	4809940E02	DTC114YE
Q12	4813824B01	PZT2222A
Q13	4809940E02	DTC114YE
Q14	4813824A10	MMBT3904
Q41	4809940E02	DTC114YE
R3	0662057A01	RES, 10
R6	NOTPLACED	RES, 10K
R7	NOTPLACED	RES, 10K
R8	NOTPLACED	RES, 10K
R9	0662057B47	RES, 0
R10	NOTPLACED	RES, 0
R11	0662057B01	RES, 130K
R12	0662057A90	RES, 51K
R13	0662057A90	RES, 51K
R14	0662057A73	RES, 10K
R15	NOTPLACED	RES, 10K
R16	0662057A83	RES, 27K
R17	0662057A76	RES, 13K
R18	0662057A49	RES, 1K
R19	0662057A73	RES, 10K
R20	NOTPLACED	RES, 10K
R21	0662057A63	RES, 3.9K
R22	0662057A45	RES, 680
R23	0662057A45	RES, 680
R24	0662057A57	RES, 2.2K
R25	0662057B47	RES, 0
R26	0662057A01	RES, 10
R27	0662057A01	RES, 10
R28	0662057B18	RES, 680K

Circuit Ref	Motorola Part No	Description
R29	0662057A81	RES, 22K
R30	NOTPLACED	RES, 10K
R31	0662057A76	RES, 13K
R33	0662057A73	RES, 10K
R34	0662057A73	RES, 10K
R35	0662057A61	RES, 3.3K
R36	0662057A89	RES, 47K
R37	0662057A89	RES, 47K
R38	0662057A89	RES, 47K
R39	0662057A73	RES, 10K
R40	0662057A73	RES, 10K
R41	0662057A73	RES, 10K
R42	NOTPLACED	RES, 0
R43	NOTPLACED	RES, 0
R44	NOTPLACED	RES, 20K
R45	0662057B47	RES, 0
R46	NOTPLACED	RES, 22K
R48	NOTPLACED	RES, 20K
R49	0662057B47	RES, 0
R50	NOTPLACED	RES, 22K
R51	0662057A88	RES, 43K
R54	0662057A76	RES, 13K
S1	NOTPLACED	TOUCH_SW
S2	NOTPLACED	TOUCH_SW
S3	NOTPLACED	TOUCH_SW
S4	NOTPLACED	TOUCH_SW
S5	NOTPLACED	TOUCH_SW
S6	NOTPLACED	TOUCH_SW
U1	5113818A01	LM2904
U2	5113805A05	MC74HCT04A
U3	5102109U01	S1D15100
U8	5113805A75	MC74HC595A
U18	NOTPLACED	LP2951C
U41	5184704M60	HEF4053B
VR1	4813830A75	MMBZ20VAL
VR2	4813830A75	MMBZ20VAL
VR3	4813830A75	MMBZ20VAL
VR4	4813830A75	MMBZ20VAL