

This service manual is the same as the TK-715/(N) (B51-8255-30) service manual with destinations T,T3,X,E,E9, and NM, with the exception of the new destinations, K.



Photo is T3 type.

CONTENTS

GENERAL	2	ADJUSTMENT	37
SYSTEM SET-UP	2	CIRCUIT DIAGRAMS / PC BOARD VIEWS	
INSTALLATION	3	PLL (X58-3970-XX)	42
REALIGNMENT	3	PLL (X58-398X-XX)	44
DISASSEMBLY FOR REPAIR	4	APC (X59-4090-50)	46
BLOCK DIAGRAM	5	HPF (X59-4100-XX)	46
LEVEL DIAGRAM	11	CONTROL UNIT (X53-3792-XX)	47
CIRCUIT DESCRIPTION	13	TX-RX UNIT (X57-424X-XX/X57-4250-21)	49
SEMICONDUCTOR DATA	19	SCHEMATIC DIAGRAM	59
DESCRIPTION OF COMPONENTS	22	TERMINAL FUNCTION	61
PARTS LIST	24	KMC-9 (BASE MICROPHONE)	61
EXPLODED VIEW	34	KPG-19 (INTERFACE CABLE)	63
PACKING	36		

GENERAL / SYSTEM SET-UP

INTRODUCTION

SCOPE OF THIS MANUAL

This manual is intended for use by experienced technicians familiar with similar types of commercial grade communications equipment. It contains all required service information for the equipment and is current as of the publication data. Changes which may occur after publication are covered by either Service Bulletins or Manual Revisions. These are issued as required.

ORDERING REPLACEMENT PARTS

When ordering replacement parts or equipment information, the full part identification number should be included. This applies to all parts : components, kits, or chassis. If the part number is not known, include the chassis or kit number of which it is a part, and a sufficient description of the required component for proper identification.

PERSONNEL SAFETY

The following precautions are recommended for personnel safety :

- DO NOT transmit if someone is within two feet (0.6 meter) of the antenna.
- DO NOT transmit until all RF connectors are verified secure and any open connectors are properly terminated.
- SHUT OFF and DO NOT operate this equipment near electrical blasting caps or in an explosive atmosphere.
- All equipment should be properly grounded before power-up for safe operation.
- This equipment should be serviced by a qualified technician only.

SYSTEM SET-UP

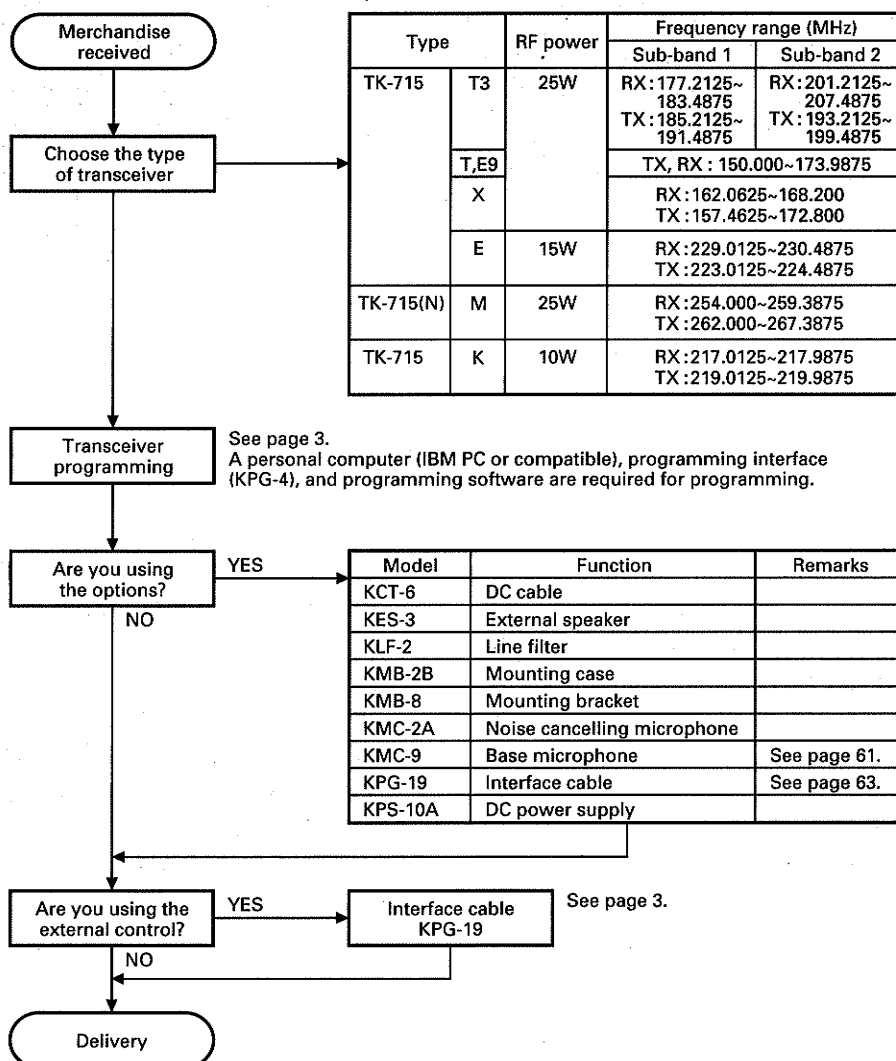

INSTALLATION / REALIGNMENT

External Control Function

1. To use this function, connect the transceiver to the IBM PC with the optional KPG-19: option interface cable .
2. The interface cable has an RS-232C TTL-level interface circuit in the D-sub connector, and the operating DC voltage is supplied to the modular connector by the transceiver. The maximum current drawn 40mA.
3. The method of connection is illustrated below.
 - 1) Remove the top half of the case and disconnect the power cable, as shown below.
 - 2) Remove the pad (G13-0688-04).
 - 3) Connect the interface cable (KPG-19) to CN3 of the control unit (X53-3792-70 : (N)M,K,X,T,T3,E or X53-3792-71 : E9).
Connect the D-sub connector to the IBM PC.
 - 4) Insert the interface cable grommet into the cable slot in the transceiver, then insert the power cable grommet. (The pad removed in 2) is not needed.)
 - 5) Put the top half of the case back on.

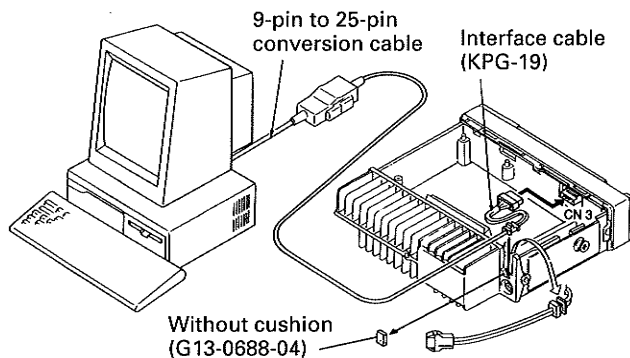

• Programming software description

The software on this disc allows a user to program TK-715/(N) radios via programming interface cable (KPG-4).

• Program mode

Data can be programmed in to the transceiver in this mode. To put the transceiver in to this mode, hold down the CALL key, switch the power on, wait for at least two seconds, then release the CALL key.

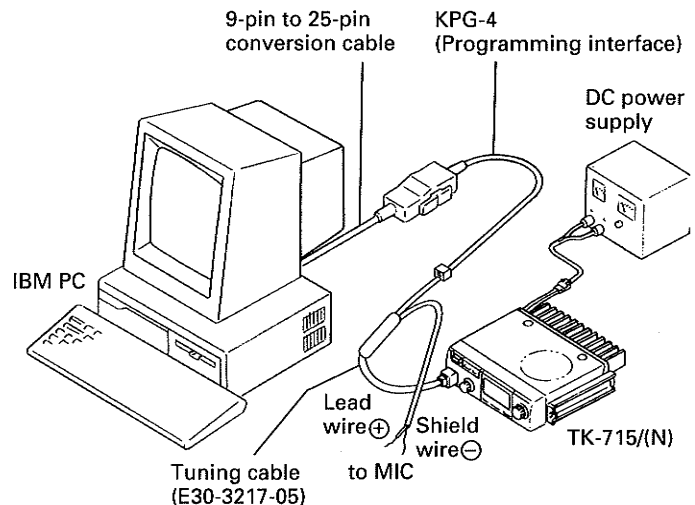

Fig. 1

REALIGNMENT

Transceiver Programming

• Introduction

The TK-715/(N) transceiver is programmed using an IBM PC or compatible machine, a programming interface (KPG-4), and a programming disc. Figure 1 shows the setup for an IBM PC.

• KPG-4 description

(P.C. programming interface cable : Option)



The KPG-4 is required to interface the TK-715/(N) to the computer. It has a circuit in its D-sub connector (25-pin) case that converts the RS-232C logic level to the TTL level.

The KPG-4 connects the front panel modular microphone connector of the TK-715/(N) to the computers RS-232C serial port.

Control Operation

Name	Description
VOL	Receive volume adjustment volume (rotation angle: 300°)
Dial	Test mode : Memory channel up/down User mode : PABX, directory, status, etc.

Display Section (LCD)

Name	Description
	ON AIR indicator
	SERVICE indicator
	NOTE indicator

TK-715/(N)

REALIGNMENT / DISASSEMBLY FOR REPAIR

Key Operation

Name	Description	
	User mode	Test mode
POWER switch	Power on/off	Power on/off
CALL	Call key Entry to conversation mode	Test mode entry FSK encode (Combined with PTT)
CLEAR	Call clear	Unused
FNC	DIR/NUM/TEL menu switching	Unused
DIGIT	Digit switching on NUMERIC menu	Set the channel step to 100 by holding down this key and turning the encoder.
ST	STACK/STATUS menu switching	Set the channel step to 10 by holding down this key and turning the encoder.

Front Panel

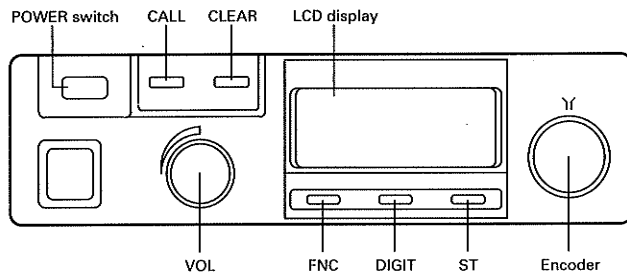

2. Pull out the CHANNEL selector knob (3) and volume control knob (4).
3. Slightly lift the stoppers holding the top and bottom of the front panel and pull out the front panel (5).
4. Remove the cushions (6).

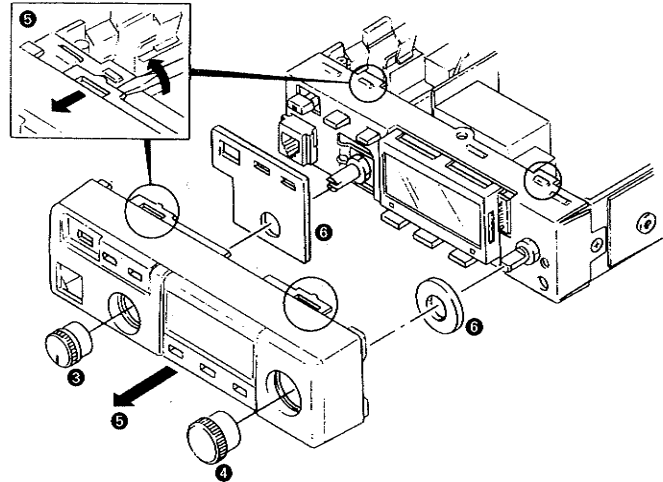

5. Remove a screw holding the LCD assy (7).
6. Pull the LCD assy forward (8).
7. Remove the hexagonal nuts of the CHANNEL selector and volume controls (9).
8. Remove the four screws on the sub-panel (10).
9. Pull the sub-panel forward.
10. Remove the two screws holding the control unit, and remove the unit (11).

DISASSEMBLY FOR REPAIR

Removing the Front Panel

1. Remove the four screws holding the guide and rail (1).
- Remove the four screws holding the upper and lower cases (2).

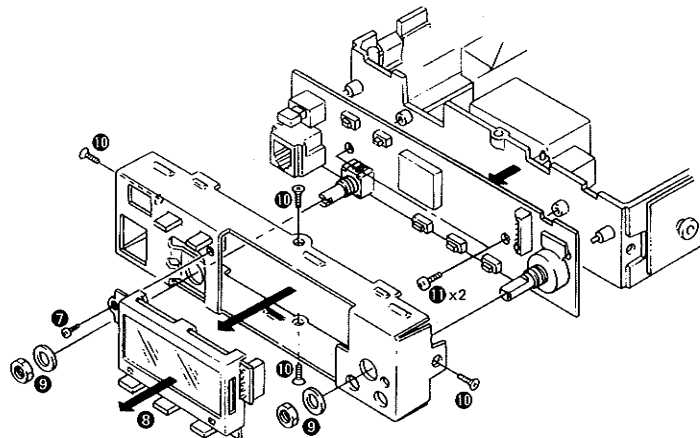
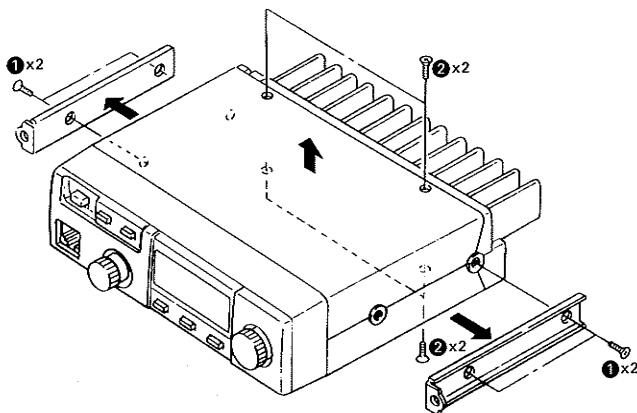

TK-715/(N) TK-715/(N)

BLOCK DIAGRAM (TK-715 : T,T3,X,E9)

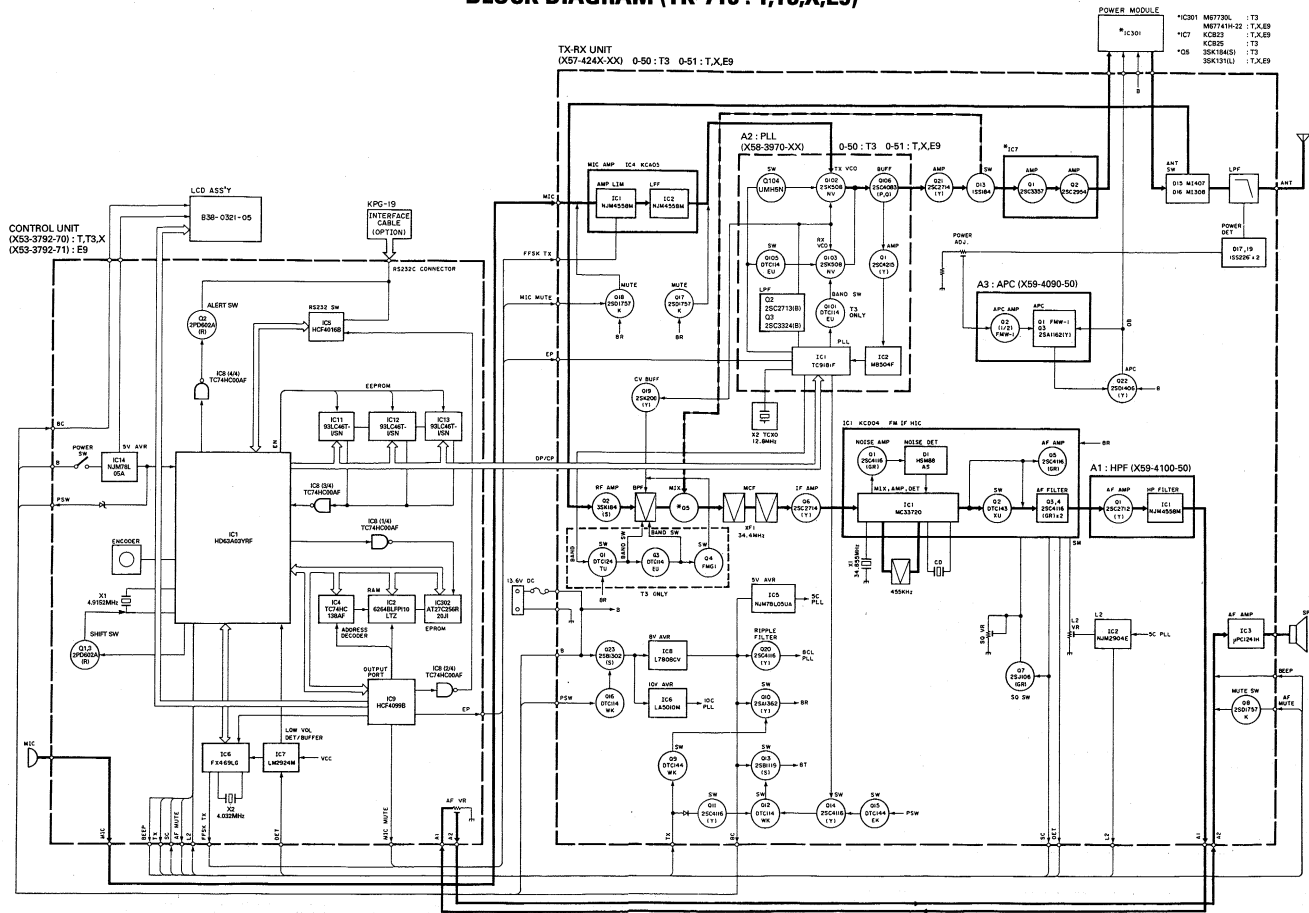

TK-715/(N) TK-715/(N)

BLOCK DIAGRAM (TK-715 : K,E)

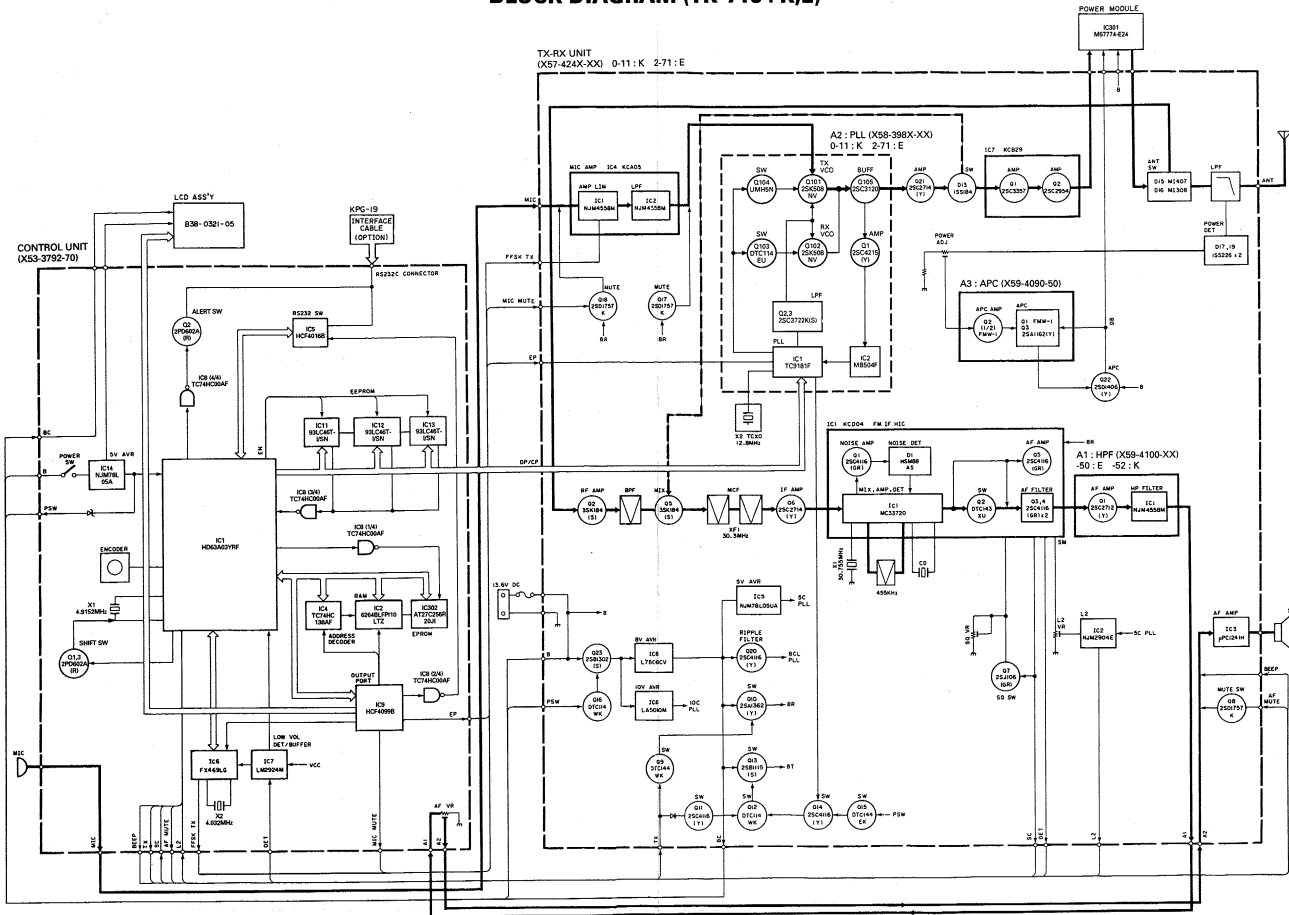

TK-715/(N) TK-715/(N) BLOCK DIAGRAM (TK-715(N) : M)

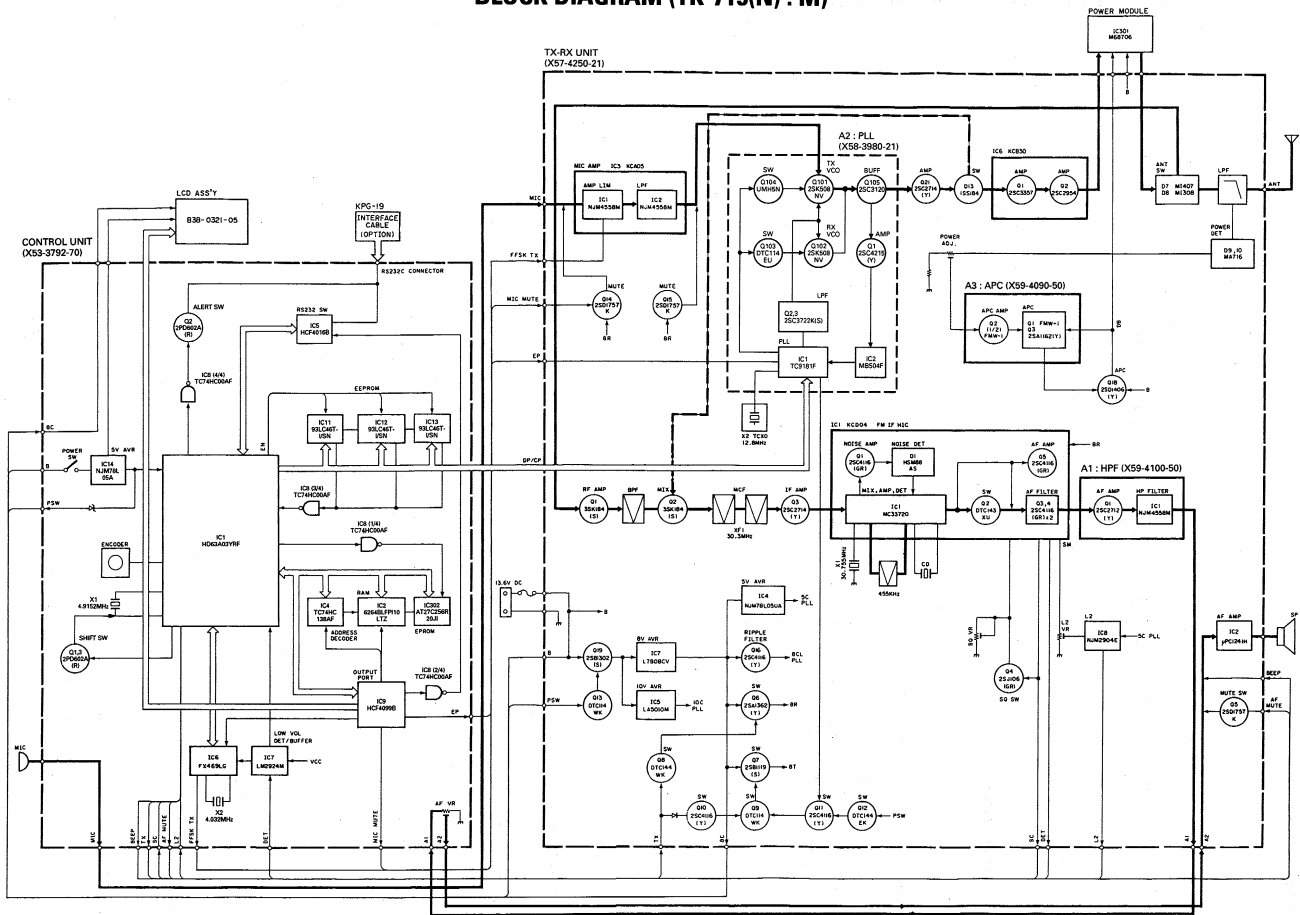

Receiver Section

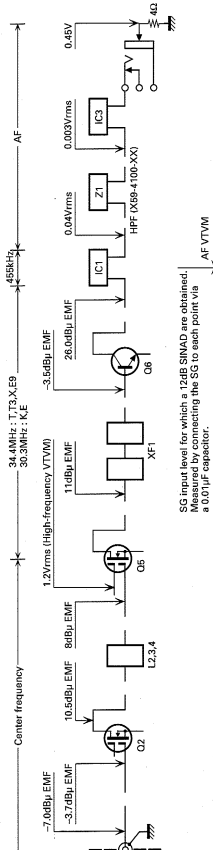

Transmitter Section

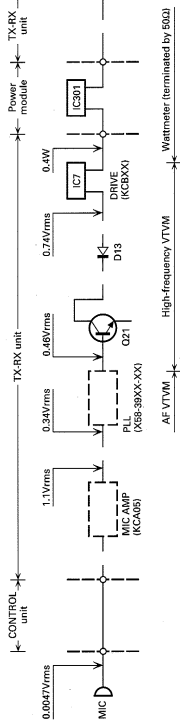

- 1. AG is set so that MIC input becomes 1.8kHz DEV at 1kHz MOD.
- 2. Transmitting frequency, Center frequency

TK-715/(N)
LEVEL DIAGRAM (TK-715 : K,T,T3,X,E,E9)

Receiver Section

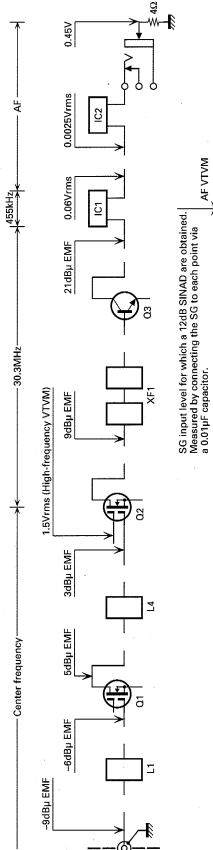

Transmitter Section

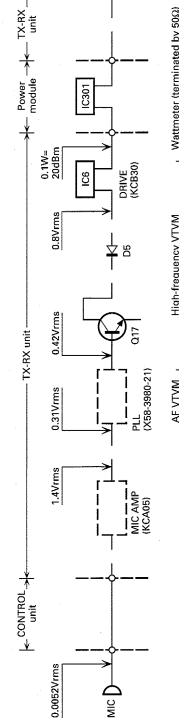

- 1. AG is set so that MIC input becomes 1.8kHz DEV at 1kHz MOD.
- 2. Transmitting frequency, Center frequency

TK-715/(N)
LEVEL DIAGRAM (TK-715(N) : M)

CIRCUIT DESCRIPTION

Circuit Configuration By Frequency

The TK-715/(N) incorporates a digital VFO that works with a PLL synthesizer.

The receiver uses on double conversion. Incoming signals are mixed with the first local oscillator signal to produce the first IF of 30.3MHz (K,E,(N)M) or 34.4MHz (T,T3,X,E9). The first IF signal is mixed with the second local oscillator signal (30.755MHz : K,E,(N)M or 34.855MHz : T,T3,X,E9) to produce the second IF of 455kHz.

The transmit signal is generated directly by the PLL circuit, and amplified by a linear amplifier.

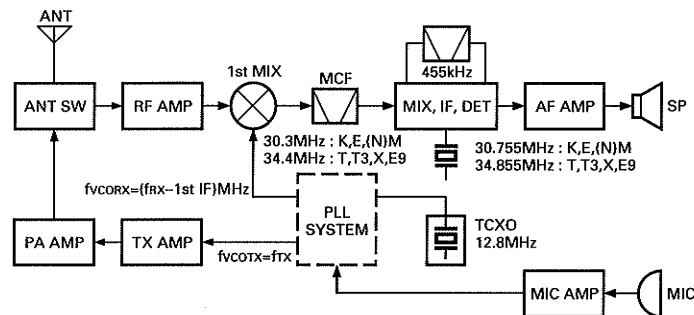

Fig. 1 Frequency configuration

Receiving System

• Overview (TK-715)

The signal received by the antenna passes through a low-pass filter in the final transmission stage, then through a transmission/reception selection circuit and an antenna matching circuit using a varicap diode in the front end section. The signal is amplified by a GaAs FET (Q2), which is able to handle the high frequencies.

The unwanted components of the signal are eliminated by a bandpass filter consisting of a three-stage variable capacitor. The resulting signal goes to the first mixer (Q5). The control voltage for the varicap diode tuning circuit is output from the CV terminal of the PLL unit. The first mixer uses an N-channel dual-gate MOS FET to provide good two-signal characteristics.

The receive signal is mixed with the first local oscillator signal from the PLL circuit (A2), and so converted to the first IF. Unwanted near-by components are eliminated by a two-stage monolithic crystal filter, and the first IF signal amplified by Q6 and input to the FM IF HIC (IC1). It is then mixed with the second local oscillator signal to produce the second IF. The second IF signal is passed through the ceramic filter (CF1), input to IC1 pin 7 amplified, and detected to produce an AF signal. The AF signal is output from IC1 pin 15, passed through the high-pass filter (A1) and AF volume, and amplified by IC3 to drive the speaker.

• Overview (TK-715(N))

Incoming signals from the antenna pass through a low-pass filter in the final block of the transmitter system, and are switched to the front-end of the receiver system via a receive/transmit switching diode.

The signals are then passed through two-pole helical resonator, where the high-frequency components are amplified by a GaAs FET. The signals are then fed into a three-pole helical resonator. The resulting signal from the second resonator is fed into the 1st mixer. The 1st mixer uses the same GaAs FET that are used in the RF stage to obtain better two-signal characteristics. The 1st mixer mixes the signal with the 1st local oscillator frequency and converts it to the 1st IF. The signal then passes through two monolithic crystal filters (MCFs) to remove unnecessary near-by frequency components. The signal from the MCFs is used as the 1st IF signal.

The 1st IF signal is amplified and fed into IC1 (KCD04) in the FM IF HIC. The IF signal is then mixed with the 2nd local oscillator frequency to generate the 2nd IF of 455kHz. The 455kHz signal is then passed through a six element ceramic filter (CFWM455G), and fed back into IC1 for additional amplification. The output signal from the IC1 is then fed into a power amplifier via the audio volume control for application to the speaker.

Item	Rating
Nominal center frequency	30.3MHz
Pass bandwidth	±3.75kHz or more at 3dB
Attenuation bandwidth	±14kHz or less at 40dB
Ripple	1.5dB or less
Insertion loss	3dB or less
Guaranteed attenuation	60dB or more within ±1MHz (Spurious : 40dB or more)
Terminating impedance	640Ω / 3pF

L71-0295-05 : TK-715 (K,E), TK-715(N) (M)

Item	Rating
Nominal center frequency	34.4MHz
Pass bandwidth	±3.75kHz or more at 3dB
Attenuation bandwidth	±14kHz or less at 40dB
Ripple	1.5dB or less
Insertion loss	3dB or less
Guaranteed attenuation	60dB or more within ±1MHz (Spurious : 40dB or more)
Terminating impedance	440Ω / 4pF

L71-0299-05 : TK-715 (T,T3,X,E9)

Table 1 MCF (TX-RX unit XF1)

Item	Rating
Nominal center frequency	455kHz
6dB bandwidth	±4.5kHz or more (from 455kHz)
50dB bandwidth	±10kHz or less (from 455kHz)
Ripple (Within ±3kHz of 455kHz)	2dB or less
Insertion loss	6dB or less
Guaranteed attenuation	35dB or more
(Within ±100kHz of 455kHz)	
I/O matching impedance	2.0kΩ

CFWM455G (L72-0376-05)

Table 2 Ceramic filter (TX-RX unit CF1)

CIRCUIT DESCRIPTION

• Band switching circuit (TK-715 : T3 only)

To implement the band plan (SUB-BAND1, SUB-BAND2) specified by the MPT1343 standard, the TK-715 has, in addition to the normal varicap tuning in the front end section a band switching circuit containing diodes and transistors (Fig. 2-1). The band is switched by the PLL (A2) band port and Q1, Q3, and Q4. (Tables 3 and 4)

Band port	SUB-BAND	Q1	Q3	Q4	D3,5,7,9
H	1	ON	ON	OFF	ON
L	2	OFF	OFF	ON	OFF

Table 3 Band switching state

SUB-BAND	Receive frequency (MHz)
1	177.2125~183.4875
2	201.2125~207.4875

Table 4 Relationship between sub-bands and receive frequencies

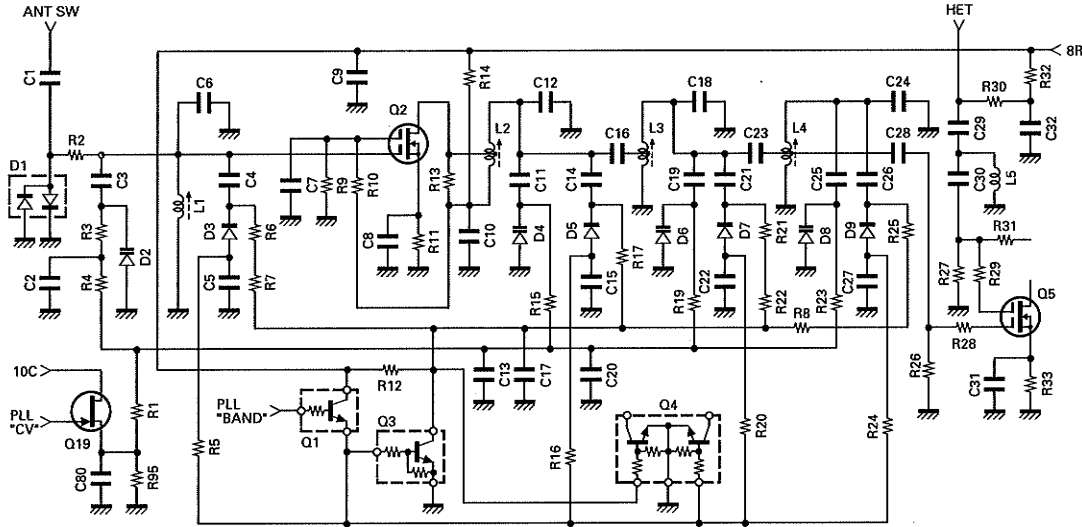

Fig. 2-1 Front-end, first mixer, varicap tuning and band switching circuits (TK-715 : T3)

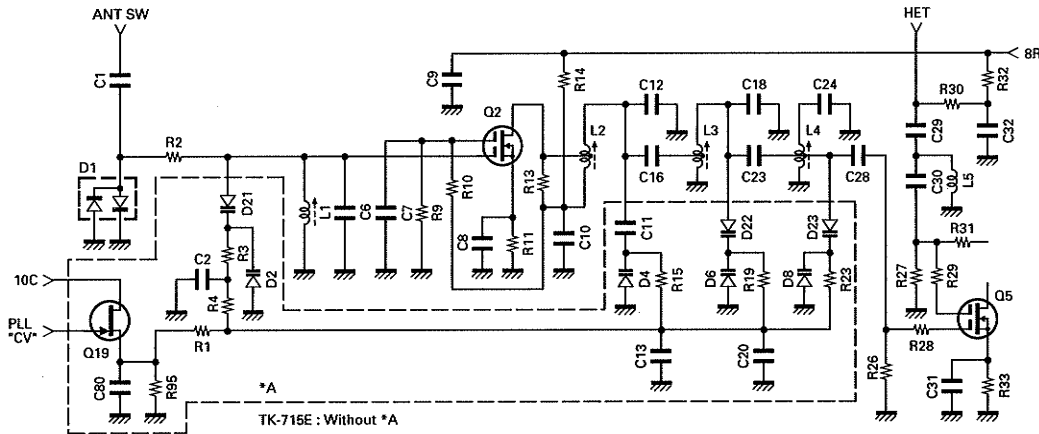

Fig. 2-2 Front-end, first mixer and varicap tuning circuits (TK-715 : K, T, X, E, E9)

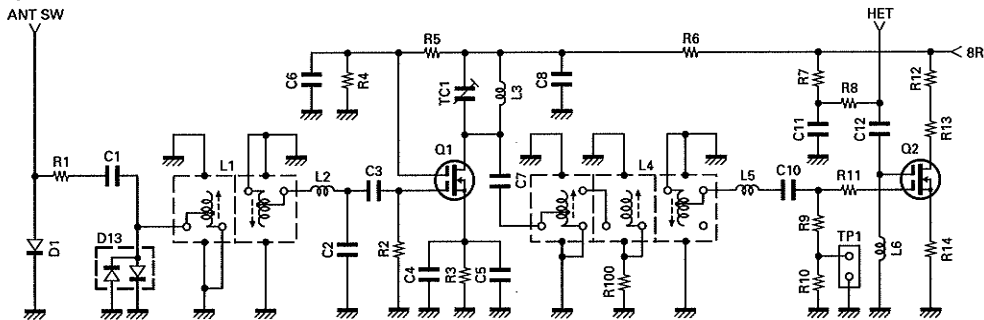

Fig. 2-3 Front-end, first mixer and varicap tuning circuits (TK-715(N) : M)

CIRCUIT DESCRIPTION

Transmitter System (TK-715 : K,T,T3,X,E,E9)

• Overview

The desired frequency for the transmit signal is generated directly by the PLL circuit. The signal is directly frequency-modulated by applying the AF signal to the varicap diode.

• Modulation circuit

The audio signal from the microphone is input to the microphone amplifier HIC (IC4). The microphone amplifier circuit has four operational amplifiers, which comprise the preemphasis, amplification, limiter, and splatter filter circuits. FM modulation is done by applying the microphone amplifier output to the varicap diode in the VCO circuit (in A2) to generate on FM signal.

• Data modulation method

As shown in the MPT1343, FFSK (Fast Frequency Shift Keying) is used for data modulation. This signal is level-ad-

justed by VR3 of the TX-RX unit from the control unit (X53-3792-70 : K,T,T3,X,E or X53-3792-71 : E9), then applied to the microphone amplifier (IC4 pin 8).

When the FFSK signal is input to the microphone amplifier, the microphone input (IC4 pin 7) is muted by Q18.

• Drive/final circuit

The output signal from the VCO is input to drive HIC (IC7) pin 11, amplified to the specified level, then power amplified by the power module (IC301). The transmit output is passed through diode switch D15 and the low-pass filter, and sent to the antenna socket.

• APC circuit

The automatic transmit output control circuit (APC) detects part of transmit output with a diode, and amplifies the resulting DC voltage to produce the control voltage. Since the control voltage is inversely proportional to the output, the transmit output is kept constant.

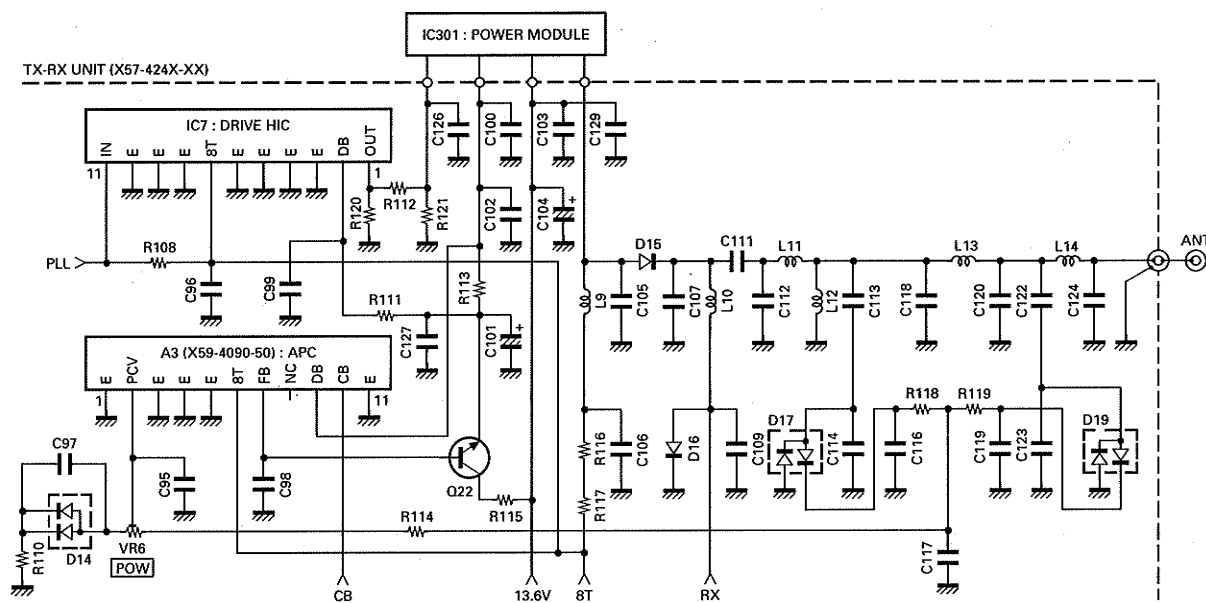

Fig. 3-1 Drive, final and APC circuits (TK-715 : K,T,T3,X,E,E9)

Transmitter System (TK-715(N) : M)

• Overview

The desired frequency for the transmit signal is generated directly by the PLL circuit. The signal is directly frequency-modulated by applying the AF signal to the varicap diode.

• Modulation circuit

The audio signal from the microphone is input to the microphone amplifier HIC (IC3). The microphone amplifier circuit has four operational amplifiers, which comprise the preemphasis, amplification, limiter, and splatter filter circuits. FM modulation is done by applying the microphone amplifier output to the varicap diode in the VCO circuit (in A2) to generate on FM signal.

CIRCUIT DESCRIPTION

• Data modulation method

As shown in the MPT1343, FFSK (Fast Frequency Shift Keying) is used for data modulation. This signal is level-adjusted by VR4 of the TX-RX unit from the control unit (X53-3792-70), then applied to the microphone amplifier (IC3 pin 8).

When the FFSK signal is input to the microphone amplifier, the microphone input (IC3 pin 7) is muted by Q14.

• Drive/final circuit

The output signal from the VCO is input to drive HIC (IC6)

pin 11, amplified to the specified level, then power amplified by the power module (IC301). The transmit output is passed through diode switch D7 and the low-pass filter, and sent to the antenna socket.

• APC circuit

The automatic transmit output control circuit (APC) detects part of transmit output with a diode, and amplifies the resulting DC voltage to produce the control voltage. Since the control voltage is inversely proportional to the output, the transmit output is kept constant.

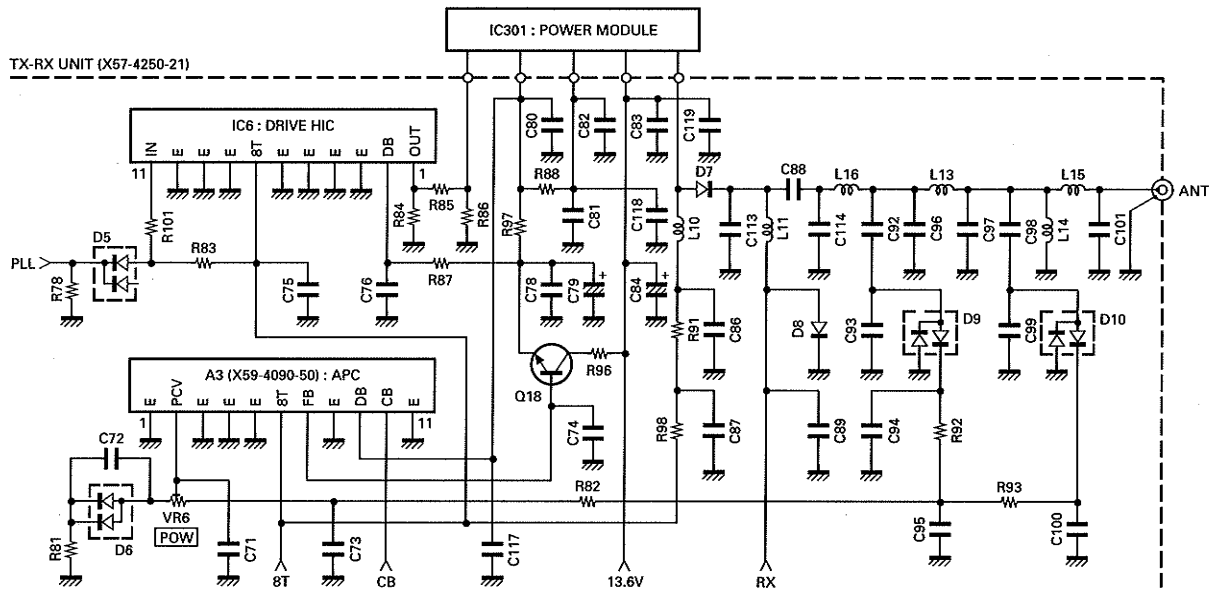

Fig. 3-2 Drive, final and APC circuits (TK-715(N) : M)

PLL Synthesizer System

• Overview

The PLL system consists of a PLL section and a VCO section. (Fig. 4)

The circuit is divided into sub-units, and the unit is housed in a rigid shield case to suppress the influence of external fields.

• Example of division

The comparison frequency of 6.25kHz (12.5kHz : K,E) is generated by dividing the 12.8MHz from the reference oscillator (X2) by 2048.

For example, 202.1250MHz is received as follows:

$$f_{VCO} = (f_{RX} - IF1) = \{(n \times 64) + A\} \times f_{ref} \div R$$

$$= (202125 - 34400) = (64n + A) \times 12800 \div 2048$$

$$\text{If } n = 419, A = 20$$

$$f_{VCO} = 26836 \times 12800 \div 2048$$

$$= 167.725\text{MHz}$$

f_{VCO} : VCO output frequency
 f_{RX} : Receive frequency
 IF1 : First IF
 n : Programmable counter setting
 A : Swallow counter setting
 f_{ref} : Reference oscillator frequency
 R : Reference divider setting

• Band switching signal (TK-715 : T3 only)

The signal (BAND) sent to the band switching circuit of the TX-RX unit is output from the PLL IC (IC1) in A2. This signal controls the front end section and VCO oscillation frequency, and provides the specified band shift. The TX signal is output from the PLL IC (IC1) during transmission to switch the oscillation transistor from Q106 to Q102.

CIRCUIT DESCRIPTION

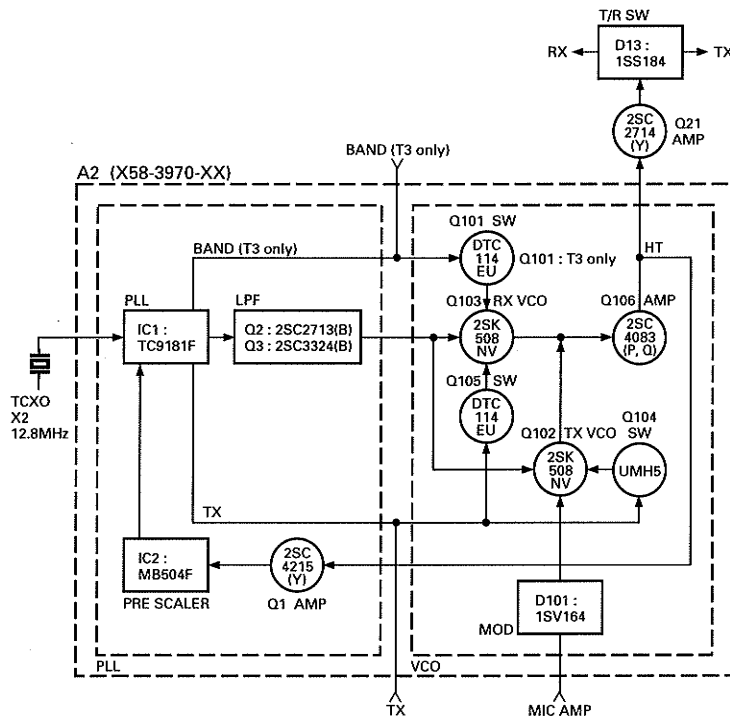

Fig. 4-1 PLL block diagram (TK-715 : T,T3,X,E9)

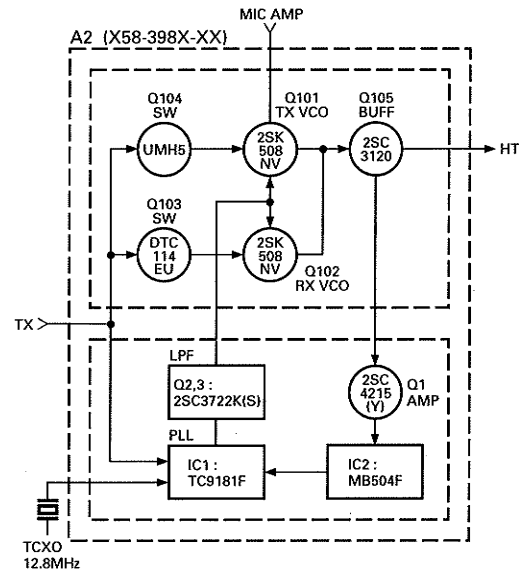

Fig. 4-2 PLL block diagram (TK-715 : K,E, TK-715(N) : M)

- **Transmit inhibit circuit when the PLL is unlocked (TK-715 : K,T,T3,X,E,E9)**

When the PLL circuit operates normally, the unlock detection voltage is low (PLL unit LD pin). If the PLL is unlocked, the detection voltage goes high, and Q14 turns on. When Q14 turns on, Q12 and Q13 turn off, and 8T (8V for transmission) output is suppressed. This stops the transmission output.

- **Transmit inhibit circuit when the PLL is unlocked (TK-715(N) : M)**

When the PLL circuit operates normally, the unlock detection voltage is low (PLL unit LD pin). If the PLL is unlocked, the detection voltage goes high, and Q11 turns on. When Q11 turns on, Q9 and Q7 turn off, and 8T (8V for transmission) output is suppressed. This stops the transmission output.

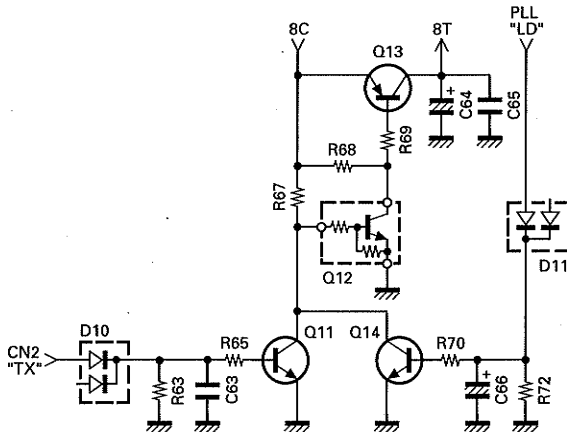

Fig. 5-1 Transmit inhibit circuit

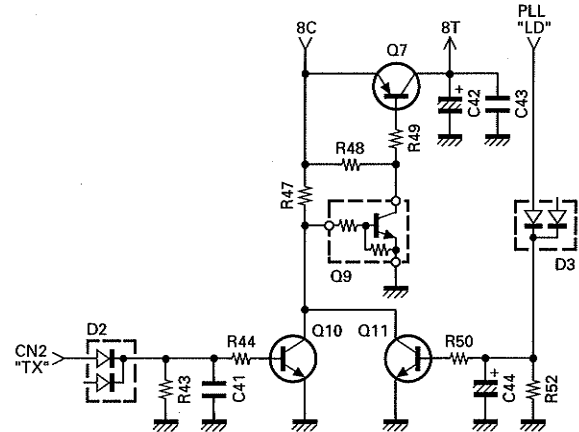

Fig. 5-2 Transmit inhibit circuit

CIRCUIT DESCRIPTION

Digital Control System

• Memory

The trunked signalling module is centred on microprocessor (IC1) and 6264 8K RAM (IC2).

The resident software is contained within a 256K EPROM (IC302).

The EPROM contains the software which characterises the way in which the mobile behaves. The frequency table which identifies the operating channels is also contained within this EPROM (OTP).

The Network Personalisation parameters for the mobile are stored in three 9346 electrical ROMs. The data which is stored is:-

- 1) Individual prefix/ident
- 2) Up to 4 group idents
- 3) Emergency ident
- 4) A directory of 20 calling prefix/idents
- 5) A directory of 4 PSTN/PABX numbers
- 6) System identity code
- 7) Electronic serial number
- 8) Control channel search table

The data is written to these EEROM's via a MIC connector at 9600 baud. A service providers utility to program the Network Personalisation Data into the mobile runs on any IBM P.C. or lap top.

• Synthesizer drive

The synthesizer is serially driven through connector CN2.

The data is SYNTH (DATA) is clocked out through SYNTH (CLK) and loaded with SYNTH (EN).

• RS232 port (IC1 : P23, P24)

The RS232 port is used for the down-loading of the Network Personalisation Data to the mobile. It may also be used as the I/O port for transmitting or receiving data. The MPT 1327/43 data modes which are supported are SDM1, SDM2 and non prescribed data. The non-prescribed data uses a protocol available in the public domain.

When using the RS232 port for Network Personalisation, access is through the MIC connector, using a KPG-4 programming cable.

When using the RS232 port for data, a KPG-19 serial interface cable is installed inside the mobile through the rear, and then connected to CN3.

The port is not a full RS232 specification. An on board level shifter and driver is provided (MAX 232) IN THE CONNECTOR CABLE. On no account should an RS232 port be directly connected to the mobile.

• FFSK interface

The mobile 'talks' to the base station (TSC) using 1200 baud FFSK signalling. Packets of data are exchanged between the mobile and the TSC during a call set-up. In addition, the mobile listens to various broadcasts from the TSC when it is idle.

The data is interfaced between the demodulator/modulator and the microprocessor by a single chip modem (IC6 : FX469LG). The tones used by FFSK are 1200 and 1800 Hz.

1) Decode

The FFSK data is buffered from the discriminator by IC7 (LM2924M). The FX469LG decodes this into a data stream for the microprocessor. In addition the FX 469 generates a 'Data Carrier Detect' signal which the microprocessor uses as one of its checks for FFSK data integrity.

2) Encode

The modem is enabled (TXEN), the PTT line forced to zero from pin 25 (P67) and data is clocked out synchronously from the microprocessor. This is converted to the 1200/1800 tones by the FX469LG and passed on to the mobile modulator. When FFSK data is being transmitted, the microphone is muted by a signal from Q1 (pin 10) of IC9.

• Busy signal

The busy signal (pin 4 CN2) from the mobile goes low when carrier is present. this is read by P55 of the microprocessor.

• CLEAR/FNC/DIGIT/ST key

CLEAR/FNC/DIGIT/ST key are interfaced through low pass filters to remove the switch bounce.

• Side tones

All confidence tone associated with call progress are generated by software and are output to pin 8 of the microprocessor (P26).

• Displays

The display is serially driven using the same DATA/CLOCK line as the synthesizer. Each segment can be individually addressed so simple characters may also be displayed.

• Supply watchdog

The supply in constantly being monitored IC7 (LM2924M). If the supply should fall to below + 8V, the microprocessor reset is pulled low. The processor then resets when the voltage returns to normal.

When the set is switched off, the micro detects that the power will fail by sensing the state of the on/off switch through R2/R37 and IC8. Valuable parameters may then be written to non volatile RAM before the power disappears.

• Supply stabilizer

The signalling board is supplied through a 78L05 regulator. This regulator is switched from the main power switch. The output from the regulator is used and an ON/OFF control for the mobile itself through the 3V zener D6. The zener diode provides a constant volt drop and ensures that the mobile will not maintain its power-up state when off through leakage.

• Alarm output

When the rear RS232 facility is not being used, the RS232 line from the microprocessor is used as a logic line to generate an alarm signal. The alarm signal on pin 1 of the RS232 connector (CN3) is low for 1 second when a individual call is received. This may be used to drive a vehicle horn or drive a small pager transmitter.

SEMICONDUCTOR DATA

Microprocessor : HD63A03YRF (Control Unit IC1)

• Terminal function

Pin No.	Port name	Pin name	Function
1	NM1	FUNC	S4 FNC key. Push : L
2	P20	RXSYNC	Rx FFSK data output
3	P21	ENCODER	Encoder switch
4	P22	RTS	RS232 connector
5	P23	RS232/IN	RS232 data input
6	P24	RS232/OUT	RS232 data output
7	P25	100/10/1	S5 DIGIT key. Push : L
8	P26	BEEP	Beep output
9	P27	ENCODER	Encoder switch
10	P50	PWR/DIN	SB check. 4.2V or less : H
11	P51	TXSYNC	Tx FFSK data output
12	P52	DCD	FFSK signal input : H
13	P53	TXDATA	Serial logic data (for FFSK) output
14	P54	RXDATA	Clocked data output
15	P55	CARRIER	Squelch busy control
16	P56	PTT	TxD/PTT
17	P57	CALL	S2 CALL key. Push : L
18	P60	RESET	S3 CLEAR key. Push : L
19	P61	P61	EEPROM EN
20	P62	P62	EEPROM EN
21	P63	P63	EEPROM EN
22	P64	P64	S6 ST key. Push : L
23	P65	MUTE	AF mute switch
24	P66	L2	L2 detect
25	P67	TX	TX : L
26	Vcc	Vcc	5C
27~34	A15~A8	A15~A8	Address bus
35	Vss	Vss	GND
36~43	A7~A0	A7~A0	Address bus
44~51	D7~D0	D7~D0	Data bus
52	BA	NC	NC
53	LIR	NC	NC
54	R/W	R/W	Read/Write EN output
55	WR	WR	NC
56	RD	RD	NC
57	E	E	System clock output
58	Vss	Vss	GND
59	XTAL	XTAL	XTAL (4.9152MHz)
60	EXTAL	EXTAL	EXTAL (4.9152MHz)
61	MP0	MP0	
62	MP1	MP1	Connected to GND
63	RES	RES	RESET input
64	STBY	STBY	Connected to 5C

FFSK Modem : FX469LG (Control Unit IC6)

• Block diagram

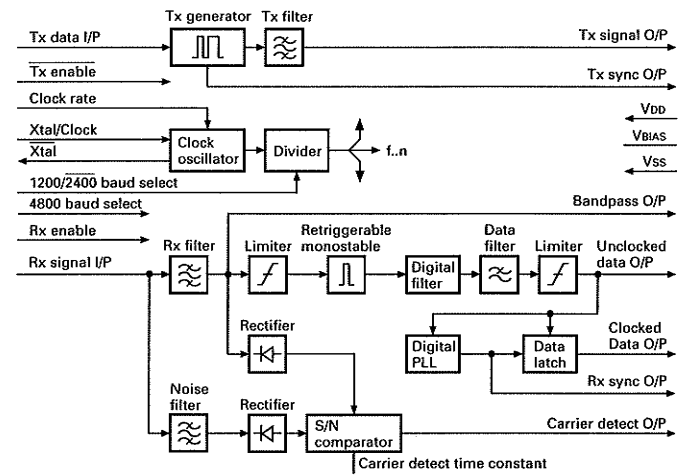

• Terminal function

Pin No.	Pin name	Function
1	Xtal/Clock	4.032MHz Xtal
2	Xtal	4.032MHz Xtal
3	Tx Sync O/P	To synchronize the input logic data
4	NC	
5	Tx Signal O/P	Tx FFSK signal output (Rx : High impedance)
6	NC	
7	Tx Data I/P	Serial logic data from IC1
8	Tx Enable	Tx : L (This pin is internally pulled to Vdd)
9	Bandpass O/P	The output of the Rx bandpass filter (NC)
10	Rx Enable	Rx : H
11	Vbias	Decoupled to Vss by C18
12	Vss	GND
13	Unclocked Data O/P	The recovered asynchronous serial data output
14	Clocked Data O/P	The recovered synchronous serial data output
15	Carrier Detect O/P	FFSK signal is received : H
16	Rx Signal I/P	FFSK signal input
17	NC	
18	Rx Sync O/P	A flywheel squarewave output
19	1200/2400/Baud Select	1200baud : (1200Hz : 1, 1800Hz : 0)
20		Internally connected
21	Clock Rate	Select Xtal (4.032MHz : H)
22	Carrier Detect Time Constant	The value of C4 connected to this pin will affect the carrier detect response time and hence noise performance
23	NC	
24	Vdd	5C

SEMICONDUCTOR DATA

TX Drive Amplifier : KCB23, KCB25, KCB29 (TX-RX Unit IC7), KCB30 (TX-RX Unit IC6)

KCB23 : TK-715 (T,X,E9), KCB25 : TK-715 (T3), KCB29 : TK-715 (K,E), KCB30 : TK-715(N) (M)

• **Block diagram**

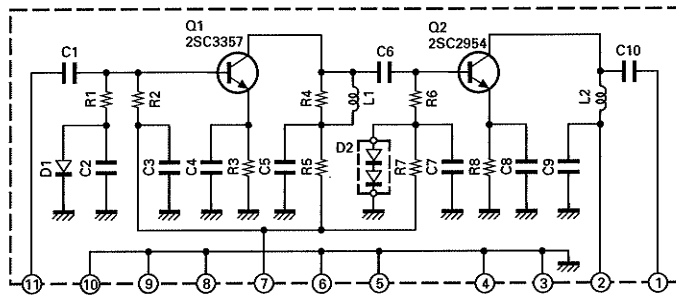

- 1 : Output
- 2 : DC power supply
- 3~6, 8~10 : GND
- 7 : DC power supply (transmitter mode)
- 11 : Input

PLL IC : TC9181F (PLL Unit IC1)

• **Block diagram**

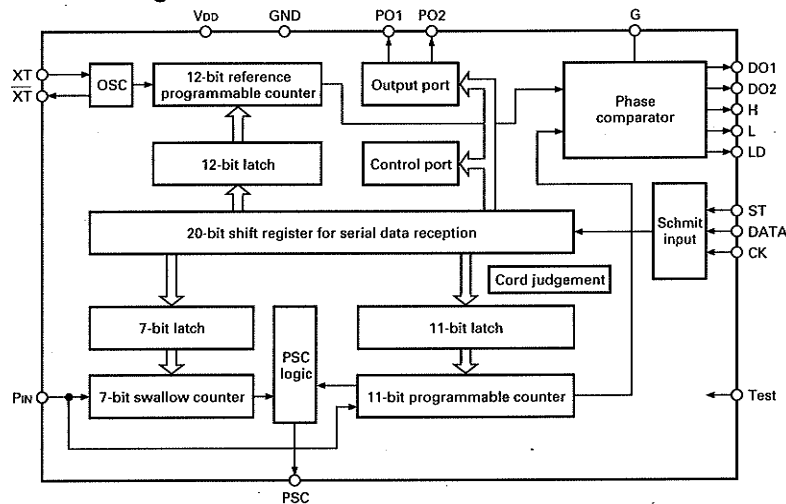

• **Maximum rating**

Ta = 25°C

Item	Symbol	Rating	Unit
Supply voltage	V _{DD}	-0.3~+7.0	V
Input voltage	V _{IN}	-0.3~V _{DD} +0.3	V
Power consumption	P _D	300	mW
Operating temperature	T _{opr}	-30~+85	°C
Storage temperature	T _{stg}	-55~+125	°C

• **Terminal function**

Pin No.	Pin name	Function
1	GND	LSI logic section ground.
2	XT	Reference frequency crystal oscillator connection.
4, 6	PO1, PO2	General output port that can be controlled externally by serial data.
9	PIN	Programmable counter input. Prescaler output C couple input.
10	PSC	2 modulus prescaler division number control signal output. "H" : P, "L" : P+1 combined with prescaler.
11	Test	Normally "L". "H" : Test state.
12, 13, 14	CK, DATA, ST	Serial data terminal for controlling the LSI externally. Schmit trigger input.
15	G	Phase comparator charge pump GND terminal.
16	LD	"H" pulse is output when the phase comparator detects phase difference. Can be reset forcibly with external data.
22, 23	DO2, DO1	DO1 : Tristate output that is always present. DO2 : Tristate output that can be turned on or off externally. Used to speed the lockup time.
24	VDD	+5V power supply terminal.

SEMICONDUCTOR DATA

Power Module : M57774-E24, M67730L, M67741H-22 (IC301)

M57774-E24 : TK-715 (K,E), M67730L : TK-715 (T3), M67741H-22 : TK-715 (T,X,E9)

• Terminal connection diagram

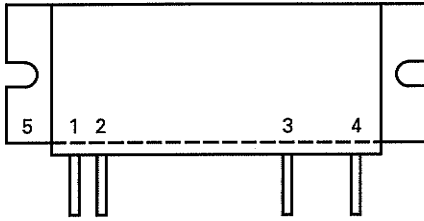

- 1 : Input
- 2 : DC power supply (first stage)
- 3 : DC power supply (final stage)
- 4 : Output
- 5 : GND (Flange)

• Maximum rating : M57774-E24/M67730L

Ta = 25°C

Item	Symbol	Condition	Rating	
			Rating	Unit
Operating voltage	Vcc		17	V
Current consumption	Icc		7	A
Input power	Pin	Vcc1 ≤ 12.5V, ZG = ZL = 50Ω	0.6	W
Output power	Pout	ZL = 50Ω	40	W
Operating case temperature	Tc(op)		-30~+110	°C
Storage temperature	Tstg		-40~+110	°C

• Maximum rating : M67741H-22

Ta = 25°C

Item	Symbol	Condition	Rating	
			Rating	Unit
Operating voltage	Vcc		17	V
Current consumption	Icc		7	A
Input power	Pin	Vcc1 ≤ 12.5V, ZG = ZL = 50Ω	0.5	W
Output power	Pout	ZL = 50Ω	35	W
Operating case temperature	Tc(op)		-30~+110	°C
Storage temperature	Tstg		-40~+110	°C

Power Module : M68706 (IC301) TK-715(N) (M)

• Terminal connection diagram

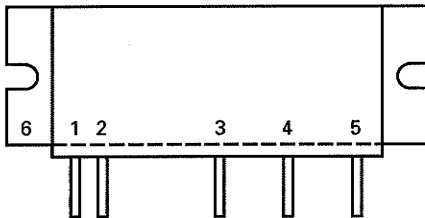

- 1 : Input
- 2 : Vcc1
- 3 : Vcc2
- 4 : Vcc
- 5 : Output
- 6 : GND (Flange)

• Maximum rating

Ta = 25°C

Item	Symbol	Condition	Rating	
			Rating	Unit
Operating voltage	Vcc		17	V
Current consumption	Icc		10	A
Input power	Pin	Vcc1 ≤ 12.5V, ZG = ZL = 50Ω	0.6	W
Output power	Pout	ZL = 50Ω	40	W
Operating case temperature	Tc(op)		-30~+110	°C
Storage temperature	Tstg		-40~+110	°C

Switching Transistor : UMH5N (PLL Unit Q104)

• Terminal connection diagram

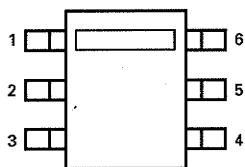

- 1 : DTr1 GND
- 2 : DTr2 GND
- 3 : DTr2 input
- 4 : DTr2 output
- 5 : DTr1 input
- 6 : DTr1 output

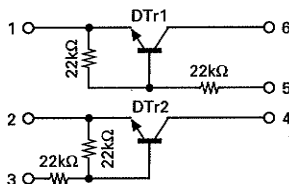

• Operating characteristics

Ta = 25°C

Item	Symbol	Condition	Rating			Unit
			MIN	TYP	MAX	
Input voltage	VI(off)	VCC = 5V, IO = 100μA	-	-	0.5	V
	VI(on)	VO = 0.2V, IO = 5mA	3.0	-	-	V
Output voltage	VO(on)	IO = 10mA, II = 0.5mA	-	0.1	0.3	V
Input current	II	VI = 5V	-	-	0.36	mA
Output current	IO(off)	VCC = 50V, VI = 0V	-	-	0.5	μA
DC current gain	GI	VO = 5V, IO = 5mA	56	-	-	-
Transition frequency	fT	VCE = 10V, IE = -5mA, f = 100MHz	-	250	-	MHz
Input resistance	R1		-	22	-	kΩ
Resistance ratio	R2/R1		0.8	1.0	1.2	-

DESCRIPTION OF COMPONENTS

CONTROL UNIT (X53-3792-XX)

-70 : TK-715 (K,T,T3,X,E), TK-715(N) (M)

-71 : TK-715 (E9)

Ref. No.	Use/Function	Operation/Condition/Compatibility
IC1	Microprocessor	Main control
IC2	S-RAM	Main control
IC4	3 to 8 line decoder	
IC5	Quad bilateral switch	
IC6	FFSK modem	
IC7	Low voltage detector /Buffer amp	
IC8	Quad NAND gate	
IC9	Addressable latch	
IC11~13	EEPROM	Network personalisation data
IC14	5V AVR	
IC302	EPROM (OTP)	Main program, Frequency table
Q1	Crystal shift	
Q2	Alert switch	
Q3	Crystal shift	
D1	Discharge	Reset
D2	Limiter	
D3	3.0V zener	Reset
D4	Discharge	Reset
D5	CPU protection	PTT
D6	CPU protection	Hook
D7	Key back light	LED

TX-RX UNIT (X57-424X-XX)

0-50 : TK-715 (T3) 0-51 : TK-715 (T,X,E9)

2-71 : TK-715 (K,E)

Ref. No.	Use/Function	Operation/Condition/Compatibility
IC1	2nd local Oscillator, IF amplification, Detection Low-frequency amplification Noise amplification Noise detection Squelch switching	1 : 1st IF signal input 3, 4 : 2nd local oscillator 9 : Busy output 10 : Squelch control 11 : S-meter output 14 : RD output 15 : Low-frequency output
IC2	Level adjust for L2 (Acquisition threshold)	Comparator operation.

Ref. No.	Use/Function	Operation/Condition/Compatibility
IC3	AF amplification	1 : AF input, 8 : output
IC4	MIC amplification	
IC5	5V AVR	
IC6	10V AVR	
IC7	TX drive amplification	
IC8	8V AVR	
Q1	Q3 switching control	On when receive mode (176~183MHz band). T3 type only
Q2	RF amplification	On in receive mode.
Q3	Q4 switching control	On when receive mode (176~183MHz band). T3 type only
Q4	Shift switching	T3 type only.
Q5	1st mixer	Converts received signals to 1st IF.
Q6	1st IF amplification	Amplifies 1st IF signal.
Q7	SQ switching	On when SQ on.
Q8	AF line mute	Operates when transmit mode, SQ is on.
Q9	8R switching control	On in receive mode.
Q10	8R switching	On in receive mode.
Q11	8T switching control	Off in transmit mode.
Q12	8T switching control	On in transmit mode.
Q13	8T switching	On in transmit mode.
Q14	8T switching control	On when PLL unlocked.
Q15	8T switching control	On when power switch off.

Q16	Power switch control	On when power switch on.
Q17	MIC amplifier mute	On in receive mode.
Q18	MIC line mute	
Q19	CV line buffer	T,T3,X,E9 type only.
Q20	PLL 8V ripple filter	
Q21	VCO output amplification	
Q22	TX drive stage +B control	
Q23	Power switch	
D1	Protection for large RX signal	
D2,4,6,8	Vari-cap tuning	T,T3,X,E9 type only.
D3,5,7,9	Band switching	T3 type only.
D10~12	Reverse current prevention	
D13	VCO output switch	
D14	Temperature compensation	
D15, 16	TX/RX switching	
D17, 19	Power detection	
D18	Reverse power protection	
D20	Surge absorber	
D21~23	Vari-cap tuning	T,X,E9 type only.

DESCRIPTION OF COMPONENTS

TX-RX UNIT (X57-4250-21) TK-715(N) (M)

Ref. No.	Use/Function	Operation/Condition/Compatibility
IC1	2nd local Oscillator, IF amplification, Detection Low-frequency amplification Noise amplification Noise detection Squelch switching	1 : 1st IF signal input 3, 4 : 2nd local oscillator 9 : Busy output 10 : Squelch control 11 : S-meter output 14 : RD output 15 : Low-frequency output
IC2	AF amplification	1 : AF input, 8 : output
IC3	MIC amplification	
IC4	5V AVR	
IC5	10V AVR	
IC6	TX drive amplification	
IC7	8V AVR	
IC8	Level adjust for L2 (Acquisition threshold)	Comparator operation.
Q1	RF amplification	On in receive mode.
Q2	1st mixer	Converts received signals to 1st IF.
Q3	1st IF amplification	Amplifies 1st IF signal.
Q4	SQ switching	On when SQ on.
Q5	AF line mute	Operates when transmit mode, SQ is on.
Q6	8R switching	On in receive mode.
Q7	8T switching	On in transmit mode.
Q8	8R switching control	On in receive mode.
Q9	8T switching control	On in transmit mode.
Q10	8T switching control	Off in transmit mode.
Q11	8T switching control	On when PLL unlocked.
Q12	8T switching control	On when power switch off.

Ref. No.	Use/Function	Operation/Condition/Compatibility
Q13	Power switch control	On when power switch on.
Q14	MIC line mute	
Q15	MIC amplifier mute	On in receive mode.
Q16	PLL 8V ripple filter	
Q17	VCO output amplification	
Q18	TX drive stage +B control	
Q19	Power switch	
D1, 7, 8	TX/RX switching	
D2~4	Reverse current prevention	
D5	VCO output switch	
D6	Temperature compensation	
D9, 10	Power detection	
D11	Reverse power protection	
D12	Surge absorber	
D13	Protection for large RX signal	

TK-715/(N)

PARTS LSIT

* New Parts. Δ indicates safety critical components.
 Parts without **Parts No.** are not supplied.
 Les articles non mentionnes dans le **Parts No.** ne sont pas fournis.
 Teile ohne **Parts No.** werden nicht geliefert.

L : Scandinavia K : USA P : Canada
 Y : PX (Far East, Hawaii) T : England E : Europe
 Y : AAFES (Europe) X : Australia M : Other Areas

TK-715/(N) CONTROL UNIT (X53-3792-XX)

Ref. No.	Address	New parts	Parts No.	Description	Desti-nation
TK-715/(N)					
1	1B		A01-1065-03	METALLIC CABINET (UPPER)	
2	3B		A01-1066-03	METALLIC CABINET (LOWER)	
3	2B		A10-1331-01	CHASSIS	
4	2A		A22-0765-23	SUB PANEL	
5	3A		A62-0228-03	PANEL ASSY	
7	3A		B03-0563-04	DRESSING PLATE	
8	3A		B10-1126-04	FRONT GLASS	
9	2A		B38-0321-05	LCD ASSY	
10	1B		B42-2455-04	LAVEL (M4X8 MAX)	
6	2B		B42-3394-14	STAND LABEL (FCC)	K
6	2B		B42-5653-04	STAND LABEL (CHASSIS)	T,T3,E,E9
20	2A	*	B42-5795-04	LAVEL (REGIONET)	K
11	1C	*	B62-0479-10	INSTRUCTION MANUAL (ENG.)	M,X,T
11	1C	*	B62-0479-10	INSTRUCTION MANUAL (ENG.)	T3,E,K
12	1C	*	B62-0567-10	INSTRUCTION MANUAL (ESPANOL)	E
12	1C	*	B62-0737-10	INSTRUCTION MANUAL (FRANCAIS)	E9
13	2B		B72-0671-04	MODEL NAME PLATE (S/NO. LABEL)	T3
13	2B		B72-0763-04	MODEL NAME PLATE (S/NO. LABEL)	X
13	2B		B72-0829-04	MODEL NAME PLATE (S/NO. LABEL)	M
13	2B		B72-0896-04	MODEL NAME PLATE (S/NO. LABEL)	E
13	2B		B72-0981-04	MODEL NAME PLATE (S/NO. LABEL)	T,E9
13	2B	*	B72-1375-14	MODEL NAME PLATE (CABINET)	K
19	3B		B72-1183-04	MODEL NAME PLATE (CABINET)	E9
14	2D		E30-2036-05	GND WIRE (MIC)	
15	2D		E30-2076-15	DC CORD ASSY	
16	1B		E30-2172-15	DC CORD	
17	2B		E30-2145-15	ANT CABLE	M,X
17	2B		E30-3031-15	ANT CABLE	E9,K
17	2B		E30-3031-15	ANT CABLE	T,T3,E
18	1B		E31-3197-15	CONNECTING WIRE (SP)	
22	2B		F10-2098-04	SHIELDING CASE	
23	3B		F10-2102-04	SHIELDING PLATE	
24	3B		F11-1133-14	SHIELDING CASE	
25	3C,2D		F51-0016-05	FUSE (10A)	
26	3B		G02-0565-04	FLAT SPRING	T,T3,E
26	3B		G02-0565-04	FLAT SPRING	X,E9,K
27	2B		G02-0576-14	FLAT SPRING	
28	3B		G02-0592-04	FLAT SPRING	
29	3B		G02-0726-04	FLAT SPRING	M
30	2B		G02-0749-04	FLAT SPRING	
31	3A		G09-0405-05	KNOB FIXED SPRING	
32	1B		G10-0651-04	NON-WOVEN FABRIC (SP)	
33	2A,2B		G10-0681-04	NON-WOVEN FABRIC (CHASSIS)	
34	1B,3B		G10-0686-04	NON-WOVEN FABRIC (CASE)	
35	2B		G13-0688-04	CUSHION (DC CORD)	
36	2A		G13-0935-04	CUSHION (SQ)	
37	3A		G13-0937-04	CUSHION (CH)	
38	3B		G13-0959-04	CUSHION (MIL)	
39	2A		G13-1418-04	CUSHION (SUB PANEL)	
40	2A		G13-1419-04	CUSHION (LCD)	
42	3C		H10-2774-02	POLYSTYRENE FORMED FIXTURE	

Ref. No.	Address	New parts	Parts No.	Description	Desti-nation
43	1C		H11-0830-04	POLYSTYRENE PLATE	
44	2D		H25-0103-04	BAG (DC CORD)	
45	2C		H25-0720-04	BAG (RADIO)	
46	3D		H52-0557-04	ITEM CARTON CASE	
48	2C		J19-1376-15	MIC HANGER	
49	1B		J19-1434-04	HOLDER (SP)	
53	1D		J29-0450-03	MOUNTING BRACKET	
54	2A,2B		J90-0405-14	GUIDE & RAIL	
-	-		J21-4287-04	MOUNTING HARDWARE	
-	-		J21-4288-04	MOUNTING HARDWARE	
-	-		J29-0447-03	MOUNTING BRACKET	
56	2A		K27-3052-04	KNOB (POW)	
57	3A		K29-4533-04	KNOB (CH)	
58	3A		K29-4534-04	KNOB (VOL.)	
59	2A		K29-4905-04	KNOB (SQ)	
61	2C		N99-0335-05	SCREW SET	
-	-		N69-4008-45	SCREW	
B	3B		N67-3008-46	SCREW (MODULE)	
C	2A,2B		N09-2230-05	SCREW	
D	1B,3B		N33-2606-45	OVAL HEAD MACHIN SCREW (CASE)	
E	2A,3A		N38-2640-46	SCREW (SUB PANEL)	
F	2B,3B		N87-2606-46	BRAZIER HEAD TAPTITESCREW (PCB)	
G	2A,2B		N88-2606-46	FLAT HEAD TAPTITE SCREW (SUB,P)	
65	1B		T07-0246-05	LOUDSPEAKER (FULLRANGE)	
66	2D		T91-0362-25	MICROPHONE	
-	-		LC7582	IC (LCD DRIVER)	
IC301	3B	*	M57774-E24	IC (POWER MODULE/220-225MHz)	E,K
IC301	3B		M67730L	IC (POWER MODULE/175-200MHz25W)	T3
IC301	3B		M67741H-22	IC (POWER MODULE/146-175MHz28W)	T,X,E9
IC301	3B		M68706	IC (POWER MODULE/250-270NH25W)	M

CONTROL UNIT (X53-3792-XX) -70 : K,T,T3,X,E,M -71 : E9

Ref. No.	Address	New parts	Parts No.	Description	Desti-nation
D7			B30-2172-05	LED (YG)	
C1,2			CC73FCH1H120J	CHIP C 12PF J	
C3			C92-0003-05	CHIP-TAN 0.47UF 25WV	
C4			CC73FCH1H470J	CHIP C 47PF J	
C5			C92-0003-05	CHIP-TAN 0.47UF 25WV	
C6,7			CK73FB1H103K	CHIP C 0.010UF K	
C8-10			CK73FB1E104K	CHIP C 0.10UF K	
C11			CK73FB1H152K	CHIP C 1500PF K	E9
C12,13			CK73FB1E104K	CHIP C 0.10UF K	
C14,15			CC73FCH1H330J	CHIP C 33PF J	
C16			CK73FB1C224K	CHIP C 0.22UF K	
C17			CK73FB1H332K	CHIP C 3300PF K	E9
C17			CK73FB1E104K	CHIP C 0.10UF K	T,T3,X
C17			CK73FB1E104K	CHIP C 0.10UF K	E,M,K
C18			CK73FB1E104K	CHIP C 0.10UF K	
C19			C92-0003-05	CHIP-TAN 0.47UF 25WV	
C20			CK73FB1E104K	CHIP C 0.10UF K	
C21			CE04NW1H4R7M	ELECTRO 4.7UF 50WV	

TK-715 : K,T,T3,X,E,E9
 TK-715(N) : M

PARTS LIST

CONTROL UNIT (X53-3792-XX)
TX-RX UNIT (X57-424X-XX)

Ref. No.	Address	New parts	Parts No.	Description	Destination	Ref. No.	Address	New parts	Parts No.	Description	Destination
C22			CE04NW1H010M	ELECTRO 1.0UF 50WV		R36			RK73FB2A103J	CHIP R 10K J 1/10W	
C23			CK73FB1E104K	CHIP C 0.10UF K		R37			RK73FB2A682J	CHIP R 6.8K J 1/10W	
C24-27			CK73FB1H102K	CHIP C 1000PF K		R38			RK73FB2A103J	CHIP R 10K J 1/10W	
C28			CK73FB1H103K	CHIP C 0.010UF K		R39,40			RK73FB2A222J	CHIP R 2.2K J 1/10W	
C29-31			CK73FB1E104K	CHIP C 0.10UF K		R41			RK73FB2A473J	CHIP R 47K J 1/10W	
C32			CE04NW1C101M	ELECTRO 100UF 16WV		R42			RK73FB2A102J	CHIP R 1.0K J 1/10W	
C33			CC73FCH1H470J	CHIP C 47PF J		R50			RD148B2E470J	RD R 47 J 1/4W	
C34			CK73FB1H102K	CHIP C 1000PF K		R51			RK73FB2A473J	CHIP R 47K J 1/10W	
C36-38			CK73FB1H102K	CHIP C 1000PF K		R52			RK73FB2A103J	CHIP R 10K J 1/10W	
C40,41			CK73FB1H102K	CHIP C 1000PF K		R53			RK73FB2A105J	CHIP R 1.0M J 1/10W	
C60,61			CK73FB1H102K	CHIP C 1000PF K		R54-56			RK73FB2A472J	CHIP R 4.7K J 1/10W	
C65			CK73FB1H102K	CHIP C 1000PF K		R58			RK73FB2A220J	CHIP R 22 J 1/10W	
C66			CK73FB1H103K	CHIP C 0.010UF K		R59			RK73FB2A472J	CHIP R 4.7K J 1/10W	
C67-69			CK73FB1H102K	CHIP C 1000PF K		R61,62			RK73FB2A102J	CHIP R 1.0K J 1/10W	
C71,72			CK73FB1H102K	CHIP C 1000PF K		R63,64			R92-0670-05	CHIP R 0 OHM	
C74			CK73FB1H103K	CHIP C 0.010UF K		R65			RK73FB2A102J	CHIP R 1.0K J 1/10W	
C76			CK73FB1H102K	CHIP C 1000PF K		R66			RK73FB2A221J	CHIP R 220 J 1/10W	
C80,81			CC73FCH1H470J	CHIP C 47PF J		R67-69			R92-0670-05	CHIP R 0 OHM	
CN1,2			E40-5203-05	PIN ASSY SOCKET 13P		R70,71			RK73FB2A122J	CHIP R 1.2K J 1/10W	
CN3			E40-5185-05	PIN ASSY 8P		R72			R92-0670-05	CHIP R 0 OHM	
CN4			E40-3485-05	PIN ASSY 6P		R73			RK73FB2A103J	CHIP R 10K J 1/10W	
CN5			E02-2033-05	IC302 SOCKET 32P		R75			RK73FB2A474J	CHIP R 470K J 1/10W	
J1			E08-0673-15	MODULAR JACK		R76			RK73FB2A472J	CHIP R 4.7K J 1/10W	
F1			F53-0054-05	FUSE 0.4A		R77,78			R92-0670-05	CHIP R 0 OHM	
L1			L92-0132-05	FERRITE CHIP		R79			RK73FB2A103J	CHIP R 10K J 1/10W	
L2-4			L92-0131-05	FERRITE CHIP		R81			R92-0670-05	CHIP R 0 OHM	E9
L6			L92-0131-05	FERRITE CHIP		R82-85			RK73FB2A473J	CHIP R 47K J 1/10W	
L7			L92-0155-05	FERRITE CHIP		VR1			R05-3452-05	POTENTIOMETER (10K)	
X1			L77-1716-05	CRYSTAL RESONATOR (4.91520MHZ)		S1			S40-2440-15	PUSH SWITCH	
X2			L77-1712-05	CRYSTAL RESONATOR (4.032MHZ)		S2-6			S40-1086-05	TACT SWITCH	
R1			RK73FB2A104J	CHIP R 100K J 1/10W		D1,2			RLS4148	DIODE	
R2			RK73FB2A153J	CHIP R 15K J 1/10W		D3			RLZ3.0(B)	ZENER DIODE	
R3			RK73FB2A473J	CHIP R 47K J 1/10W		D4			RLS4148	DIODE	
R4			RK73FB2A103J	CHIP R 10K J 1/10W		D5,6			1SS226	DIODE	
R5-7			RK73FB2A104J	CHIP R 100K J 1/10W		IC1			HD63A03YRF	IC (8BIT MICRO PROSESSOR)	
R8,9			RK73FB2A222J	CHIP R 2.2K J 1/10W		IC2			6264BLFP110LTZ	IC (S RAM)	
R10			RK73FB2A474J	CHIP R 470K J 1/10W		IC4			TC74HC138AF	IC (DECODER)	
R11-13			RK73FB2A104J	CHIP R 100K J 1/10W		IC5			HCF4016B	IC (QUAD BILATERAL SWITCH)	
R14,15			RK73FB2A222J	CHIP R 2.2K J 1/10W		IC6			FX469LG	IC (1200/2400/4800 FULL DUPLEX)	
R16,17			RK73FB2A104J	CHIP R 100K J 1/10W		IC7			LM2924M	IC (LOW POWER AMP)	
R18			RK73FB2A102J	CHIP R 1.0K J 1/10W		IC8			TC74HC00AF	IC (2INPUT NAND GATE)	
R19,20			RK73FB2A103J	CHIP R 10K J 1/10W		IC9			HCF4099B	IC (ADDRESSABLE LATCH)	
R21			RK73FB2A105J	CHIP R 1.0M J 1/10W		IC11-13			93LC46BT-I/SN	IC (EEP ROM)	
R22			RK73FB2A472J	CHIP R 4.7K J 1/10W		IC14			NJM78L05A	IC (VOLTAGE REGULATOR/ +5V)	
R23			RK73FB2A222J	CHIP R 2.2K J 1/10W		IC302			AT27C256R20JI	IC (EP ROM (OTP)) CNS SOCKET	
R24			RK73FB2A682J	CHIP R 6.8K J 1/10W		Q1-3			2PD602A(R)	TRANSISTOR	
R25			RK73FB2A473J	CHIP R 47K J 1/10W		S7			W02-0866-05	ENCODER	
R25			RK73FB2A473J	CHIP R 47K J 1/10W		TX-RX UNIT (X57-424X-XX)					
R25			RK73FB2A224J	CHIP R 220K J 1/10W		0-11 : K 0-50 : T3 0-51 : T,X,E9 2-71 : E					
R26			RK73FB2A153J	CHIP R 15K J 1/10W		C1			CC73FCH1H030C	CHIP C 3.0PF C	
R27			RK73FB2A103J	CHIP R 10K J 1/10W		C2			CK73FB1H103K	CHIP C 0.010UF K	T,T3,X,E9
R28,29			RK73FB2A473J	CHIP R 47K J 1/10W		C3			CC73FCH1H120J	CHIP C 12PF J	T3
R30			RK73FB2A105J	CHIP R 1.0M J 1/10W		C4			CC73FCH1H050C	CHIP C 5.0PF C	T3
R31			RK73FB2A223J	CHIP R 22K J 1/10W		C5			CK73FB1H102K	CHIP C 1000PF K	T3
R32			RK73FB2A220J	CHIP R 22 J 1/10W							
R33			RK73FB2A472J	CHIP R 4.7K J 1/10W							
R34,35			RK73FB2A222J	CHIP R 2.2K J 1/10W							

TK-715 : K,T,T3,X,E,E9

TK-715(N) : M

PARTS LIST

TX-RX UNIT (X57-424X-XX)

Ref. No.	Address	New parts	Parts No.	Description	Destination	Ref. No.	Address	New parts	Parts No.	Description	Destination
C6			CC73FCH1H020C	CHIP C 2.0PF C	T3	C51			CK73FB1H103K	CHIP C 0.010UF K	
C6			CC73FCH1H040C	CHIP C 4.0PF C	E	C52,53			CE04EW1C470M	ELECTRO 47UF 16WV	
C6			CC73FCH1H050C	CHIP C 5.0PF C	K	C54,55			CE04EW1A470M	ELECTRO 47UF 10WV	
C7,8			CK73FB1H102K	CHIP C 1000PF K		C56			CK73FB1E273K	CHIP C 0.027UF K	T,T3,X
C9			CK73FB1H103K	CHIP C 0.010UF K		C56			CK73FB1E273K	CHIP C 0.027UF K	E,E9
C10			CK73FB1H102K	CHIP C 1000PF K		C56			CK73FB1H332K	CHIP C 3300PF K	K
C11			CC73FCH1H080D	CHIP C 8.0PF D	T3	C57			CC73FCH1H101J	CHIP C 100PF J	
C11			CC73FCH1H330J	CHIP C 33PF J	T,X,E9	C58			CE04EW1C100M	ELECTRO 10UF 16WV	
C12			CC73FCH1H020C	CHIP C 2.0PF C	T3	C59,60			CK73FF1C105Z	CHIP C 1.0UF Z	
C12			CC73FCH1H090D	CHIP C 9.0PF D	E	C61			CK73FB1H103K	CHIP C 0.010UF K	
C12			CC73FCH1H100D	CHIP C 10PF D	K	C62			CE04EW1A470M	ELECTRO 47UF 10WV	
C13			CK73FB1H102K	CHIP C 1000PF K	T,T3,X,E9	C63			CK73FB1H273K	CHIP C 0.027UF K	
C14			CC73FCH1H030C	CHIP C 3.0PF C	T3	C64			CE04EW1C100M	ELECTRO 10UF 16WV	T3
C15			CK73FB1H102K	CHIP C 1000PF K	T3	C64			CE04EW1H3R3M	ELECTRO 3.3UF 50WV	T,X,E,E9
C16			CC73FCH1H0R5C	CHIP C 0.5PF C	T,X,E,E9	C65			CK73FB1H103K	CHIP C 0.010UF K	
C16			CC73FCH1H010C	CHIP C 1.0PF C	T3	C66			C92-0511-05	CHIP-TAN 0.15UF 35WV	
C17			CK73FB1H102K	CHIP C 1000PF K	T3	C67			CK73FB1H102K	CHIP C 1000PF K	
C18			CC73FCH1H020C	CHIP C 2.0PF C	T3	C68			CK73FB1H183K	CHIP C 0.018UF K	
C18			CC73FCH1H030C	CHIP C 3.0PF C	T,X,E9	C69,70			CK73FB1H102K	CHIP C 1000PF K	
C18			CC73FCH1H080D	CHIP C 8.0PF D	E	C71			CK73FB1H471K	CHIP C 470PF K	
C18			CC73FCH1H100D	CHIP C 10PF D	K	C72			CK73FB1H183K	CHIP C 0.018UF K	T3
C19			CC73FCH1H070D	CHIP C 7.0PF D	T3	C72			CK73FF1C105Z	CHIP C 1.0UF Z	T,X,E9
C20			CK73FB1H102K	CHIP C 1000PF K	T,T3,X,E9	C72			CK73FF1C105Z	CHIP C 1.0UF Z	E,K
C21			CC73FCH1H040C	CHIP C 4.0PF C	T3	C73			CK73FB1H103K	CHIP C 0.010UF K	
C22			CK73FB1H102K	CHIP C 1000PF K	T3	C74			CE04EW1A470M	ELECTRO 47UF 10WV	
C23			CC73FCH1H0R5C	CHIP C 0.5PF C	T,X,E,E9	C75			CK73FB1H102K	CHIP C 1000PF K	
C23			CC73FCH1H010C	CHIP C 1.0PF C	T3	C76			CC73FCH1H100D	CHIP C 10PF D	
C24			CC73FCH1H0R5C	CHIP C 0.5PF C	T,X,E9	C77-79			CC73FCH1H470J	CHIP C 47PF J	
C24			CC73FCH1H020C	CHIP C 2.0PF C	T3	C80			CK73FB1H102K	CHIP C 1000PF K	T,T3,X,E9
C24			CC73FCH1H080D	CHIP C 8.0PF D	E	C81			CK73FB1H103K	CHIP C 0.010UF K	
C24			CC73FCH1H100D	CHIP C 10PF D	K	C82			CE04EW1A221M	ELECTRO 220UF 10WV	
C25			CC73FCH1H070D	CHIP C 7.0PF D	T3	C83,84			CK73FB1H102K	CHIP C 1000PF K	T,T3,X,E9
C26			CC73FCH1H040C	CHIP C 4.0PF C	T3	C85			CE04EW1A221M	ELECTRO 220UF 10WV	
C27			CK73FB1H102K	CHIP C 1000PF K	T3	C86,87			CK73FB1H102K	CHIP C 1000PF K	
C28			CC73FCH1H100D	CHIP C 10PF D	E	C88			CK73FB1H103K	CHIP C 0.010UF K	
C28			CC73FCH1H150J	CHIP C 15PF J	T,T3,X,E9	C89			CK73FB1H102K	CHIP C 1000PF K	
C28			CC73FCH1H150J	CHIP C 15PF J	K	C90			CC73FCH1H060D	CHIP C 6.0PF D	T3
C29			CC73FCH1H030C	CHIP C 3.0PF C	E	C90			CC73FCH1H100D	CHIP C 10PF D	E,K
C29			CC73FCH1H150J	CHIP C 15PF J	K	C90			CC73FCH1H220J	CHIP C 22PF J	T,X,E9
C29			CC73FCH1H060D	CHIP C 6.0PF D	T3	C91			CK73FB1H102K	CHIP C 1000PF K	
C29			CC73FCH1H100D	CHIP C 10PF D	T,X,E9	C92			CK73FB1H103K	CHIP C 0.010UF K	
C30			CK73FB1H471K	CHIP C 470PF K		C93			CC73FCH1H060D	CHIP C 6.0PF D	T3
C31,32			CK73FB1H102K	CHIP C 1000PF K		C93			CC73FCH1H100D	CHIP C 10PF D	E,K
C33			CK73FB1H103K	CHIP C 0.010UF K		C93			CC73FCH1H220J	CHIP C 22PF J	T,X,E9
C34			CC73FCH1H040C	CHIP C 4.0PF C	T,T3,X,E9	C94			CE04EW1C471M	ELECTRO 470UF 16WV	
C35			CK73FB1H102K	CHIP C 1000PF K		C95-98			CK73FB1H102K	CHIP C 1000PF K	
C36			CC73FCH1H220J	CHIP C 22PF J		C99			CK73FF1C105Z	CHIP C 1.0UF Z	
C37			CC73FCH1H040C	CHIP C 4.0PF C	T3	C100			CK73FB1H102K	CHIP C 1000PF K	
C38			CK73FB1H103K	CHIP C 0.010UF K		C101			CE04EW1C470M	ELECTRO 47UF 16WV	
C39			CE04EW1A470M	ELECTRO 47UF 10WV		C102			CK73FF1C105Z	CHIP C 1.0UF Z	
C40			CK73FB1E223K	CHIP C 0.022UF K		C103			CK73FB1H102K	CHIP C 1000PF K	
C41,42			CK73FB1H102K	CHIP C 1000PF K		C104			CE04EW1C100M	ELECTRO 10UF 16WV	
C43			CC73FCH1H470J	CHIP C 47PF J		C105			CC45SL2H030C	CERAMIC 3.0PF C	E,K
C44			CK73FB1H102K	CHIP C 1000PF K		C105			CC45SL2H090D	CERAMIC 9.0PF D	T3
C45			CC73FCH1H390J	CHIP C 39PF J		C106			CK73FB1H102K	CHIP C 1000PF K	
C46			CK73FF1C105Z	CHIP C 1.0UF Z		C107			CC45SL2H120J	CERAMIC 12PF J	T,X,E9
C47			C92-0004-05	CHIP-TAN 1.0UF 16WV		C107			CC45SL2H220J	CERAMIC 22PF J	T3,E,K
C48,49			CK73FB1E104K	CHIP C 0.10UF K		C108			CK73FB1H103K	CHIP C 0.010UF K	
C50			CE04EW1A471M	ELECTRO 470UF 10WV		C109			CC73FCH1H050C	CHIP C 5.0PF C	E,K

TK-715 : K,T,T3,X,E,E9

TK-715(N) : M

PARTS LIST

TX-RX UNIT (X57-424X-XX)

Ref. No.	Address	New parts	Parts No.	Description	Destination	Ref. No.	Address	New parts	Parts No.	Description	Destination
C109			CC73FCH1H090D	CHIP C 9.0PF D	T,X,E9	L15			L79-0558-05	FILTER	
C109			CC73FCH1H120J	CHIP C 12PF J	T3	X1			L77-1415-05	CRYSTAL RESONATOR (34.855MHZ)	T,T3,X,E9
C110			CE04EW1A470M	ELECTRO 47UF 10WV		X1			L77-1419-05	CRYSTAL RESONATOR (30.755MHZ)	E,K
C111			CK45B2H102K	CERAMIC 1000PF K		X2			L77-1376-35	TCXO (12.8MHZ)	T,T3,X
C112			CM73F2H040D	CHIP C 4.0PF D	T3,E,K	X2			L77-1376-35	TCXO (12.8MHZ)	E9,E
C112			CM73F2H220J	CHIP C 22PF J	T,X,E9	X2		*	L77-1729-05	TCXO (12.8MHZ)	K
C113			CC73FCH1H0R5B	CHIP C 0.5PF B		XF1			L71-0295-05	CRYSTAL FILTER (30.3MHZ)	E,K
C114			CC73FCH1H020C	CHIP C 2.0PF C		XF1			L71-0299-05	CRYSTAL FILTER (34.4MHZ)	T,T3,X,E9
C115			CK73FB1H103K	CHIP C 0.010UF K		R1			RK73FB2A473J	CHIP R 47K J 1/10W	T,T3,X,E9
C116,117			CK73FB1H102K	CHIP C 1000PF K		R2			R92-0670-05	CHIP R 0 OHM	
C118			CC45SL2H220J	CERAMIC 22PF J	E,K	R3			RK73FB2A104J	CHIP R 100K J 1/10W	T,T3,X,E9
C118			CC45SL2H330J	CERAMIC 33PF J	T3	R4			R92-0670-05	CHIP R 0 OHM	T,T3,X,E9
C118			CC45SL2H390J	CERAMIC 39PF J	T,X,E9	R5,6			RK73FB2A103J	CHIP R 10K J 1/10W	T3
C119			CK73FB1H102K	CHIP C 1000PF K		R7,8			R92-0670-05	CHIP R 0 OHM	T3
C120			CC45SL2H180J	CERAMIC 18PF J	E,K	R9			RK73FB2A103J	CHIP R 10K J 1/10W	T,X,E9
C120			CC45SL2H270J	CERAMIC 27PF J	T3	R9			RK73FB2A222J	CHIP R 2.2K J 1/10W	T3
C120			CC45SL2H390J	CERAMIC 39PF J	T,X,E9	R9			R92-0670-05	CHIP R 0 OHM	E,K
C121			CK73FB1H103K	CHIP C 0.010UF K		R10			RK73FB2A274J	CHIP R 270K J 1/10W	T,X,E,E9,K
C122			CC73FCH1H0R5B	CHIP C 0.5PF B		R10			RK73FB2A473J	CHIP R 47K J 1/10W	T3
C123			CC73FCH1H020C	CHIP C 2.0PF C		R11			RK73FB2A101J	CHIP R 100 J 1/10W	
C124			CC45SL2H050C	CERAMIC 5.0PF C	E,K	R12			RK73FB2A473J	CHIP R 47K J 1/10W	T3
C124			CC45SL2H100D	CERAMIC 10PF D	T3	R13			RK73FB2A103J	CHIP R 10K J 1/10W	
C124			CC45SL2H150J	CERAMIC 15PF J	T,X,E9	R14			RK73FB2A101J	CHIP R 100 J 1/10W	
C125			CE04EW1C102M	ELECTRO 1000UF 16WV		R15			RK73FB2A104J	CHIP R 100K J 1/10W	T,T3,X,E9
C126			CC73FCH1H080D	CHIP C 8.0PF D	E,K	R16,17			RK73FB2A103J	CHIP R 10K J 1/10W	T3
C127			CC73ECH1H101J	CHIP C 100PF J		R19			RK73FB2A104J	CHIP R 100K J 1/10W	T,T3,X,E9
C128,129			CC73FCH1H101J	CHIP C 100PF J		R20,21			RK73FB2A103J	CHIP R 10K J 1/10W	T3
CN1			E40-3237-05	PIN CONNECTOR (SP)		R22			R92-0670-05	CHIP R 0 OHM	T3
CN2,3			E40-5202-05	PIN CONNECTOR (13P)		R23			RK73FB2A104J	CHIP R 100K J 1/10W	T,T3,X,E9
CN4			E40-5328-05	PIN CONNECTOR (3P)		R24,25			RK73FB2A103J	CHIP R 10K J 1/10W	T3
J1			E11-0448-05	PHONE JACK (EX SP)		R26			RK73FB2A473J	CHIP R 47K J 1/10W	
J2			E18-0254-05	SOCKET (SET/USE 2P)		R27			RK73FB2A333J	CHIP R 33K J 1/10W	T3,E,K
TP1			E23-0465-05	TERMINAL (SM)		R27			RK73FB2A473J	CHIP R 47K J 1/10W	T,X,E9
TP2			E23-0465-05	TERMINAL (CV)		R28			RK73FB2A330J	CHIP R 33 J 1/10W	T,X,E,E9,K
W1			E33-1902-05	FINISHED WIRE SET (HET)		R28			R92-0670-05	CHIP R 0 OHM	T3
-			J30-0545-05	SPACER		R29			RK73FB2A470J	CHIP R 47 J 1/10W	
CD1			L79-1013-05	CERAMIC DISCRI (CDBM455C16)		R30			RK73FB2A102J	CHIP R 1.0K J 1/10W	
CF1			L72-0376-05	CERAMIC FILTER (CFWM455G)		R31			RK73FB2A274J	CHIP R 270K J 1/10W	
L1-4			L34-4080-05	COIL	T,X,E9	R32			R92-0670-05	CHIP R 0 OHM	
L1-4			L34-4103-05	COIL	T3,E,K	R33			RK73FB2A100J	CHIP R 10 J 1/10W	T,X,E9
L2-4			L34-4324-05	COIL	T3	R33			RK73FB2A470J	CHIP R 47 J 1/10W	T3,E,K
L5			L40-1081-80	SMALL FIXED INDUCTOR (100nH)	E	R34			RK73FB2A101J	CHIP R 100 J 1/10W	
L5			L40-1085-48	SMALL FIXED INDUCTOR (100nH)	K	R35			RK73FB2A102J	CHIP R 1.0K J 1/10W	T3
L5			L40-1281-80	SMALL FIXED INDUCTOR (120nH)	T3	R35			RK73FB2A222J	CHIP R 2.2K J 1/10W	E,K
L5			L40-1581-80	SMALL FIXED INDUCTOR (150nH)	T,X,E9	R35			RK73FB2A472J	CHIP R 4.7K J 1/10W	T,X,E9
L6			L34-2157-05	COIL	E,K	R36			RK73FB2A101J	CHIP R 100 J 1/10W	T3
L6			L34-4191-05	COIL	T,T3,X,E9	R36			RK73FB2A271J	CHIP R 270 J 1/10W	T,X,E9
L7,8			L40-1092-19	SMALL FIXED INDUCTOR (1UH)		R36			RK73FB2A471J	CHIP R 470 J 1/10W	E,K
L9			L34-1239-05	COIL		R37			RK73EB2B101J	CHIP R 100 J 1/8W	
L10			L34-0895-05	COIL	T,X,E9	R38			RK73FB2A391J	CHIP R 390 J 1/10W	T3
L10			L34-1207-05	COIL	T3,E,K	R38			RK73FB2A471J	CHIP R 470 J 1/10W	T,X,E,E9,K
L11			L34-0742-05	COIL	T,X,E9	R39			RK73FB2A224J	CHIP R 220K J 1/10W	
L11			L34-1193-15	COIL	T3	R40			RK73FB2A101J	CHIP R 100 J 1/10W	
L11			L34-1208-05	COIL	E,K	R41			RK73FB2A471J	CHIP R 470 J 1/10W	
L12			L34-0908-05	COIL		R42			R92-0670-05	CHIP R 0 OHM	
L13,14			L34-0499-05	COIL	T,T3,X,E9	R43			RK73FB2A153J	CHIP R 15K J 1/10W	
L13,14			L34-1127-05	COIL	E,K	R44			RK73FB2A101J	CHIP R 100 J 1/10W	
						R45			R92-0670-05	CHIP R 0 OHM	

TK-715 : K,T,T3,X,E,E9

TK-715(N) : M

PARTS LIST

TX-RX UNIT (X57-424X-XX)

Ref. No.	Address	New parts	Parts No.	Description	Destination	Ref. No.	Address	New parts	Parts No.	Description	Destination
R46			RK73FB2A103J	CHIP R 10K J 1/10W		R108			RK73FB2A102J	CHIP R 1.0K J 1/10W	
R47			RK73FB2A105J	CHIP R 1.0M J 1/10W		R109			R92-0685-05	CHIP R 22 J 1/2W	
R48			RK73FB2A473J	CHIP R 47K J 1/10W		R110			R92-0670-05	CHIP R 0 OHM	
R49			R92-0670-05	CHIP R 0 OHM		R111			R92-0699-05	CHIP R 10 J 1/2W	
R50			RK73FB2A104J	CHIP R 100K J 1/10W		R112			RK73FB2A5R6J	CHIP R 5.6 J 1/10W	
R51			RK73FB2A223J	CHIP R 22K J 1/10W		R113			R92-0679-05	CHIP R 0 OHM	
R52			RK73FB2A683J	CHIP R 68K J 1/10W		R114			RK73FB2A823J	CHIP R 82K J 1/10W	
R53			R92-1220-05	CHIP R 1.0 K 1/10W		R115			R92-0679-05	CHIP R 0 OHM	
R54			RK73FB2A680J	CHIP R 68 J 1/10W	T,T3,X	R116			R92-1213-05	CHIP R 100 J 1/2W	
R54			RK73FB2A680J	CHIP R 68 J 1/10W	E9,E	R117			R92-0670-05	CHIP R 0 OHM	
R54			RK73EB2B101J	CHIP R 100 J 1/10W	K	R118,119			RK73FB2A223J	CHIP R 22K J 1/10W	
R55			RK73FB2A473J	CHIP R 47K J 1/10W		R120,121			RK73FB2A102J	CHIP R 1.0K J 1/10W	
R56			RK73FB2A333J	CHIP R 33K J 1/10W		VR1,2			R12-6744-05	TRIMMING POT (47K)	
R57			RK73FB2A822J	CHIP R 8.2K J 1/10W		VR3			R32-0622-05	TRIMMING POT (47K)	
R58			RK73FB2A223J	CHIP R 22K J 1/10W		VR4			R32-0618-05	TRIMMING POT (10K)	
R59			RK73FB2A472J	CHIP R 4.7K J 1/10W		VR5			R12-6744-05	TRIMMING POT (47K)	
R60			RK73FB2A473J	CHIP R 47K J 1/10W		VR6			R32-0621-05	TRIMMING POT (33K)	T,T3,X,E9
R61			RK73FB2A822J	CHIP R 8.2K J 1/10W		VR6			R32-0622-05	TRIMMING POT (47K)	E,K
R62			R92-0670-05	CHIP R 0 OHM		D1			1SS226	DIODE	
R63			RK73FB2A334J	CHIP R 330K J 1/10W		D2			1SV164	VARI-CAP DIODE	T,T3,X
R64			RK73FB2A182J	CHIP R 1.8K J 1/10W		D3			MA77	DIODE	T,T3,X,E9
R65			RK73FB2A223J	CHIP R 22K J 1/10W		D4			1SV164	VARI-CAP DIODE	T,T3,X
R66-68			RK73FB2A103J	CHIP R 10K J 1/10W		D5			MA77	DIODE	T,T3,X,E9
R69			RK73FB2A182J	CHIP R 1.8K J 1/10W		D6			1SV164	VARI-CAP DIODE	T3
R70			RK73FB2A223J	CHIP R 22K J 1/10W		D6			1SV166	VARI-CAP DIODE	T,X,E9
R71,72			RK73FB2A473J	CHIP R 47K J 1/10W		D7			MA77	DIODE	T3
R73			R92-0670-05	CHIP R 0 OHM		D8			1SV164	VARI-CAP DIODE	T,T3,X,E9
R74			R92-1215-05	CHIP R 470 J 1/2W		D9			MA77	DIODE	T3
R75			RK73FB2A103J	CHIP R 10K J 1/10W		D10-13			1SS184	DIODE	
R76			RK73FB2A273J	CHIP R 27K J 1/10W		D14			1SS181	DIODE	
R77			RK73FB2A394J	CHIP R 390K J 1/10W		D15			M1407	DIODE	
R78,79			R92-0670-05	CHIP R 0 OHM		D16			M1308	DIODE	
R80			RK73FB2A681J	CHIP R 680 J 1/10W		D17			1SS226	DIODE	
R81			RK73FB2A102J	CHIP R 1.0K J 1/10W		D18			DSA3A1	SURGE ABSORBER	
R82			RK73FB2A103J	CHIP R 10K J 1/10W		D19			1SS226	DIODE	
R83			RK73FB2A223J	CHIP R 22K J 1/10W		D20			ERZ-M10DK220	SARGE ABSORBER	
R84			R92-0670-05	CHIP R 0 OHM		D21-23			1SV164	VARI-CAP DIODE	T,X,E9
R85			RK73FB2A152J	CHIP R 1.5K J 1/10W		IC1			KC004	IC (FM/IF)	
R86,87			R92-0670-05	CHIP R 0 OHM		IC2			NJM2904E	IC (OP AMP X2)	
R88			RK73FB2A220J	CHIP R 22 J 1/10W		IC3			UPC1241H	IC (AF POWER AMP)	
R89			RK73FB2A152J	CHIP R 1.5K J 1/10W		IC4			KCA05	IC (MIC AMP)	
R90			RK73FB2A103J	CHIP R 10K J 1/10W		IC5			NJM78L05UA	IC (VOLTAGE REGULATOR/ +5V)	
R91			R92-0670-05	CHIP R 0 OHM		IC6			LA5010M	IC (LOW SATURATION REGULATOR)	
R92			RK73FB2A102J	CHIP R 1.0K J 1/10W		IC7			KCB23	IC (DRIVE AMP)	T,X,E9
R93,94			R92-0670-05	CHIP R 0 OHM		IC7			KCB25	IC (DRIVE AMP /184-200MHz)	T3
R95			RK73FB2A104J	CHIP R 100K J 1/10W	T,T3,X,E9	IC7			KCB29	IC (DSIVE AMP /220MHz)	E,K
R96			RK73FB2A471J	CHIP R 470 J 1/10W	T,T3,X,E9	IC8			L7808CV	IC (VOLTAGE REGULATOR/ +8V)	
R97			R92-0670-05	CHIP R 0 OHM		Q1			DTC124TU	DIGITAL TRANSISTOR	T3
R98			RK73FB2A105J	CHIP R 1.0M J 1/10W	T,T3,X,E9	Q2			3SK184(S)	FET	
R99			RK73FB2A102J	CHIP R 1.0K J 1/10W		Q3			DTC114EU	DIGITAL TRANSISTOR	T3
R100			RK73FB2A122J	CHIP R 1.2K J 1/10W		Q4			FMG1	DIGITAL TRANSISTOR	T3
R101			RK73FB2A220J	CHIP R 22 J 1/10W		Q5			3SK131(L)	FET	T,X,E9
R102			RK73FB2A223J	CHIP R 22K J 1/10W		Q5			3SK184(S)	FET	T3,E,K
R103			RK73FB2A103J	CHIP R 10K J 1/10W	T,X,E9	Q6			2SC2714(Y)	TRANSISTOR	
R103			RK73FB2A103J	CHIP R 10K J 1/10W	E,T3	Q7			2SJ106(GR)	FET	
R103			RK73FB2A333J	CHIP R 33K J 1/10W	K	Q8			2SD1757K	TRANSISTOR	
R104,105			RK73FB2A101J	CHIP R 100 J 1/10W		Q9			DTC144WK	DIGITAL TRANSISTOR	
R106			RK73FB2A102J	CHIP R 1.0K J 1/10W		Q10			2SA1362(Y)	TRANSISTOR	
R107			R92-0670-05	CHIP R 0 OHM							

TK-715 : K,T,T3,X,E,E9
TK-715(N) : M

PARTS LIST

TX-RX UNIT (X57-424X-XX)

TX-RX UNIT (X57-4250-21)

Ref. No.	Address	New parts	Parts No.	Description	Destination	Ref. No.	Address	New parts	Parts No.	Description	Destination
Q11			2SC4116(Y)	TRANSISTOR		C41			CK73FB1H273K	CHIP C	0.027UF K
Q12			DTC114WK	DIGITAL TRANSISTOR		C42			CE04EW1H3R3M	ELECTRO	3.3UF 50WV
Q13			2SB1119(S)	TRANSISTOR		C43			CK73FB1E103K	CHIP C	0.010UF K
Q14			2SC4116(Y)	TRANSISTOR		C44			C92-0511-05	CHIP-TAN	0.15UF 35WV
Q15			DTC144EK	DIGITAL TRANSISTOR		C45			CK73FB1H102K	CHIP C	1000PF K
Q16			DTC114WK	DIGITAL TRANSISTOR		C46			CK73FB1H183K	CHIP C	0.018UF K
Q17,18			2SD1757K	TRANSISTOR		C47-49			CK73FB1H102K	CHIP C	1000PF K
Q19			2SK208(Y)	FET	T,T3,X,E9	C50			CC73FCH1H471J	CHIP C	470PF J
Q20			2SC4116(Y)	TRANSISTOR		C51			CK73FF1C105Z	CHIP C	1.0UF Z
Q21			2SC2714(Y)	TRANSISTOR		C52			CK73FB1H102K	CHIP C	1000PF K
Q22			2SD1406(Y)	TRANSISTOR		C53,54			CK73FB1H103K	CHIP C	0.010UF K
Q23			2SB1302(S)	TRANSISTOR		C55			CE04EW1A470M	ELECTRO	47UF 10WV
A1			X59-4100-50	HPF UNIT	T3,E,T	C56			CE04EW1C100M	ELECTRO	10UF 16WV
A1			X59-4100-50	HPF UNIT	X,E9	C57			CE04EW1A221M	ELECTRO	220UF 10WV
A1		*	X59-4100-52	HPF UNIT	K	C58			CK73FB1H103K	CHIP C	0.010UF K
A2			X58-3970-50	PLL UNIT	T3	C60			CK73FB1H102K	CHIP C	1000PF K
A2			X58-3970-51	PLL UNIT	T,X,E9	C62			CC73FCH1H101J	CHIP C	100PF J
A2		*	X58-3980-11	PLL UNIT	K	C63			CC73FCH1H070D	CHIP C	7.0PF D
A2			X58-3982-71	PLL UNIT	E	C64,65			CK73FB1H102K	CHIP C	1000PF K
A3			X59-4090-50	APC UNIT		C66			CC73FCH1H070D	CHIP C	7.0PF D
TX-RX UNIT (X57-4250-21) : M						C67			CK73FB1H102K	CHIP C	1000PF K
C1			CC73FCH1H471J	CHIP C	470PF J	C68			CC73FCH1H101J	CHIP C	100PF J
C2			CC73FCH1H0R5C	CHIP C	0.5PF C	C69			CK73FB1H103K	CHIP C	0.010UF K
C3			CC73FCH1H560J	CHIP C	56PF J	C70			CE04EW1C471M	ELECTRO	470UF 16WV
C4			CC73FCH1H101J	CHIP C	100PF J	C71-75			CK73FB1H102K	CHIP C	1000PF K
C5,6			CK73FB1H102K	CHIP C	1000PF K	C76			CK73FF1C105Z	CHIP C	1.0UF Z
C7			CC73FCH1H030C	CHIP C	3.0PF C	C78			CK73FB1H102K	CHIP C	1000PF K
C8			CK73FB1H102K	CHIP C	1000PF K	C79			CE04EW1C470M	ELECTRO	47UF 16WV
C10			CC73FCH1H560J	CHIP C	56PF J	C80,81			CK73FF1C105Z	CHIP C	1.0UF Z
C11			CK73FB1H102K	CHIP C	1000PF K	C82			CK73FB1H102K	CHIP C	1000PF K
C12			CC73FCH1H030C	CHIP C	3.0PF C	C83			CC73FCH1H101J	CHIP C	100PF J
C13,14			CK73FB1H102K	CHIP C	1000PF K	C84			CE04EW1C100M	ELECTRO	10UF 16WV
C15			CC73FCH1H220J	CHIP C	22PF J	C86			CC73FCH1H471J	CHIP C	470PF J
C16,17			CK73FB1H102K	CHIP C	1000PF K	C87			CK73FB1H102K	CHIP C	1000PF K
C18			CE04EW1A470M	ELECTRO	47UF 10WV	C88			CK45B2H102K	CERAMIC	1000PF K
C19			CK73FB1H102K	CHIP C	1000PF K	C89			CC73FCH1H100D	CHIP C	10PF D
C20			CC73FCH1H470J	CHIP C	47PF J	C92			CC73FCH1H0R5B	CHIP C	0.5PF B
C21			CC73FCH1H390J	CHIP C	39PF J	C93			CC73FCH1H020C	CHIP C	2.0PF C
C22			CK73FB1H102K	CHIP C	1000PF K	C94,95			CK73FB1H102K	CHIP C	1000PF K
C23			CK73FF1C105Z	CHIP C	1.0UF Z	C96,97			CC45SL2H180J	CERAMIC	18PF J
C24			C92-0004-05	CHIP-TAN	1.0UF 16WV	C98			CC73FCH1H0R5B	CHIP C	0.5PF B
C25			CK73FB1E104K	CHIP C	0.10UF K	C99			CC73FCH1H020C	CHIP C	2.0PF C
C26			CK73FB1H102K	CHIP C	1000PF K	C100			CK73FB1H102K	CHIP C	1000PF K
C27			CK73FB1E104K	CHIP C	0.10UF K	C101			CM73F2H090D	CHIP C	9.0PF D
C28			CE04EW1A471M	ELECTRO	470UF 10WV	C102			CK73FB1H103K	CHIP C	0.010UF K
C29			CE04EW1C470M	ELECTRO	47UF 16WV	C103			CE04EW1C100M	ELECTRO	10UF 16WV
C30			CK73FB1E103K	CHIP C	0.010UF K	C104,105			CK73FB1H103K	CHIP C	0.010UF K
C31			CE04EW1C470M	ELECTRO	47UF 16WV	C106			C90-2092-05	ELECTRO	1800UF 16WV
C32,33			CE04EW1A470M	ELECTRO	47UF 10WV	C109			CC73FCH1H100D	CHIP C	10PF D
C34			CK73FB1H273K	CHIP C	0.027UF K	C110-112			CC73FCH1H470J	CHIP C	47PF J
C35			CK73FF1C105Z	CHIP C	1.0UF Z	C113			CC45SL2H080D	CERAMIC	8.0PF D
C36			CE04EW1C100M	ELECTRO	10UF 16WV	C114			CC45SL2H090D	CERAMIC	9.0PF D
C37			CC73FCH1H101J	CHIP C	100PF J	C115			CC73FCH1H101J	CHIP C	100PF J
C38			CK73FF1C105Z	CHIP C	1.0UF Z	C116			CC73FCH1H470J	CHIP C	47PF J
C39			CK73FB1E103K	CHIP C	0.010UF K	C117,118			CC73FCH1H101J	CHIP C	100PF J
C40			CE04EW1A470M	ELECTRO	47UF 10WV	C119			CC73FCH1H470J	CHIP C	47PF J
						TC1			C05-0348-05	TRIM CAP	6PF
						CN1			E40-3237-05	PIN CONNECTOR (SP)	

TK-715 : K,T,T3,X,E,E9

TK-715(N) : M

PARTS LSIT

TX-RX UNIT (X57-4250-21)

Ref. No.	Address	New parts	Parts No.	Description	Destination	Ref. No.	Address	New parts	Parts No.	Description	Destination
CN2,3			E40-5202-05	PIN CONNECTOR (13P)		R33			RK73FB2A680J	CHIP R 68 J 1/10W	
CN4			E40-5328-05	PIN CONNECTOR (3P)		R35			RK73FB2A473J	CHIP R 47K J 1/10W	
J1			E11-0448-05	PHONE JACK (EX SP)		R36			RK73FB2A333J	CHIP R 33K J 1/10W	
J2			E18-0254-05	SOCKET (SET/USE 2P)		R37			RK73FB2A223J	CHIP R 22K J 1/10W	
TP1			E40-0211-05	PIN CONNECTOR (2P)		R38			RK73FB2A472J	CHIP R 4.7K J 1/10W	
TP2-4			E23-0465-05	TERMINAL		R39,40			RK73FB2A822J	CHIP R 8.2K J 1/10W	
W1			E33-1902-05	FINISHED WIRE SET (HET)		R42			RK73FB2A473J	CHIP R 47K J 1/10W	
			J30-0545-05	SPACER		R43			RK73FB2A334J	CHIP R 330K J 1/10W	
CD1			L79-1013-05	CERAMIC DISCRI (CDBM455C16)		R44			RK73FB2A223J	CHIP R 22K J 1/10W	
CF1			L72-0376-05	CERAMIC FILTER (CPWM455G)		R45			RK73FB2A182J	CHIP R 1.8K J 1/10W	
L1			L79-1160-05	HELICAL (257MHZ)		R46-48			RK73FB2A103J	CHIP R 10K J 1/10W	
L2			L40-1081-80	SMALL FIXED INDUCTOR (100nH)		R49			RK73FB2A182J	CHIP R 1.8K J 1/10W	
L3			L40-3972-80	SMALL FIXED INDUCTOR (39nH)		R50			RK73FB2A223J	CHIP R 22K J 1/10W	
L4			L79-1161-05	HELICAL (257MHZ)		R51			R92-0670-05	CHIP R 0 OHM	
L5			L40-1081-80	SMALL FIXED INDUCTOR (100nH)		R52,53			RK73FB2A473J	CHIP R 47K J 1/10W	
L6			L40-5672-80	SMALL FIXED INDUCTOR (56nH)		R54			R92-0670-05	CHIP R 0 OHM	
L7			L34-2157-05	COIL		R55			RK73FB2A102J	CHIP R 1.0K J 1/10W	
L8			L40-1092-81	SMALL FIXED INDUCTOR (1.0UH)		R56			RK73FB2A681J	CHIP R 680 J 1/10W	
L9			L40-6872-80	SMALL FIXED INDUCTOR (68nH)		R57			RK73FB2A394J	CHIP R 390K J 1/10W	
L10			L34-0908-05	COIL		R58			RK73FB2A472J	CHIP R 4.7K J 1/10W	
L11			L34-1207-05	COIL		R59,60			R92-0670-05	CHIP R 0 OHM	
L13			L34-1059-05	COIL		R61			RK73FB2A152J	CHIP R 1.5K J 1/10W	
L14			L34-0908-05	COIL		R62			RK73FB2A103J	CHIP R 10K J 1/10W	
L15,16			L34-1059-05	COIL		R63			RK73FB2A152J	CHIP R 1.5K J 1/10W	
L17			L79-0558-05	FILTER		R64			RK73FB2A103J	CHIP R 10K J 1/10W	
X1			L77-1419-05	CRYSTAL RESONATOR (30.755MHz)		R65			R92-0670-05	CHIP R 0 OHM	
X2			L77-1376-35	TCXO (12.8MHz)		R66			RK73FB2A220J	CHIP R 22 J 1/10W	
XF1			L71-0295-05	CRYSTAL FILTER (30.3MHz)		R67-70			R92-0670-05	CHIP R 0 OHM	
R1			R92-0670-05	CHIP R 0 OHM		R71			RK73FB2A122J	CHIP R 1.2K J 1/10W	
R2			RK73FB2A333J	CHIP R 33K J 1/10W		R72			RK73FB2A220J	CHIP R 22 J 1/10W	
R3			RK73FB2A101J	CHIP R 100 J 1/10W		R73			RK73FB2A102J	CHIP R 1.0K J 1/10W	
R4			RK73FB2A103J	CHIP R 10K J 1/10W		R74			RK73FB2A472J	CHIP R 4.7K J 1/10W	
R5			RK73FB2A104J	CHIP R 100K J 1/10W		R75			RK73FB2A222J	CHIP R 2.2K J 1/10W	
R6			RK73FB2A101J	CHIP R 100 J 1/10W		R76,77			RK73FB2A101J	CHIP R 100 J 1/10W	
R7,8			RK73FB2A102J	CHIP R 1.0K J 1/10W		R78			RK73FB2A222J	CHIP R 2.2K J 1/10W	
R9			RK73FB2A223J	CHIP R 22K J 1/10W		R79			R92-0670-05	CHIP R 0 OHM	
R10			RK73FB2A102J	CHIP R 1.0K J 1/10W		R80			R92-0685-05	CHIP R 22 J 1/2W	
R11			RK73FB2A220J	CHIP R 22 J 1/10W		R81			R92-0670-05	CHIP R 0 OHM	
R12			RK73FB2A470J	CHIP R 47 J 1/10W		R82			RK73FB2A823J	CHIP R 82K J 1/10W	
R13			RK73FB2A222J	CHIP R 2.2K J 1/10W		R83,84			RK73FB2A102J	CHIP R 1.0K J 1/10W	
R14			RK73FB2A470J	CHIP R 47 J 1/10W		R85			RK73FB2A5R6J	CHIP R 5.6 J 1/10W	
R15,16			RK73FB2A471J	CHIP R 470 J 1/10W		R86			RK73FB2A102J	CHIP R 1.0K J 1/10W	
R17			RK73FB2A334J	CHIP R 330K J 1/10W		R87			R92-0699-05	CHIP R 10 J 1/2W	
R18			RK73FB2A102J	CHIP R 1.0K J 1/10W		R88			R92-0679-05	CHIP R 0 OHM	
R19			RK73FB2A101J	CHIP R 100 J 1/10W		R89			R92-1214-05	CHIP R 120 J 1/2W	
R20			RK73EB2B101J	CHIP R 100 J 1/8W		R92,93			RK73FB2A103J	CHIP R 10K J 1/10W	
R21			RK73FB2A153J	CHIP R 15K J 1/10W		R94			R92-1215-05	CHIP R 470 J 1/2W	
R22			RK73FB2A101J	CHIP R 100 J 1/10W		R95			RK73FB2A103J	CHIP R 10K J 1/10W	
R23			R92-0670-05	CHIP R 0 OHM		R96,97			R92-0679-05	CHIP R 0 OHM	
R24			RK73FB2A683J	CHIP R 68K J 1/10W		R98			R92-0670-05	CHIP R 0 OHM	
R25			RK73FB2A273J	CHIP R 27K J 1/10W		R99			RK73FB2A102J	CHIP R 1.0K J 1/10W	
R26			R92-0670-05	CHIP R 0 OHM		R100			R92-0670-05	CHIP R 0 OHM	
R27			RK73FB2A105J	CHIP R 1.0M J 1/10W		R101			RK73FB2A100J	CHIP R 10 J 1/10W	
R28			RK73FB2A103J	CHIP R 10K J 1/10W		VR1,2			R12-6744-05	TRIMMING POT (47K)	
R29			RK73FB2A473J	CHIP R 47K J 1/10W		VR3			R32-0618-05	TRIMMING POT (10K)	
R30			RK73FB2A104J	CHIP R 100K J 1/10W		VR4			R32-0622-05	TRIMMING POT (47K)	
R31			RK73FB2A223J	CHIP R 22K J 1/10W		VR5			R12-6744-05	TRIMMING POT (47K)	
R32			RK73FB2A1R0J	CHIP R 1.0 J 1/10W		VR6			R32-0621-05	TRIMMING POT (33K)	

PARTS LIST

TX-RX UNIT (X57-4250-21)
PLL (X58-3970-XX)

Ref. No.	Address	New parts	Parts No.	Description	Destination	Ref. No.	Address	New parts	Parts No.	Description	Destination
D1			M1308	DIODE		C18,19			CK73FB1H102K	CHIP C 1000PF K	
D2-4			1SS184	DIODE		C20			C92-0555-05	CHIP-TAN 0.047UF 35WV	
D5			DAN235K	DIODE		C21			CK73FB1E104K	CHIP C 0.10UF K	T,X,E9
D6			1SS181	DIODE		C22			CC73FCH1H100D	CHIP C 10PF D	
D7			M1407	DIODE		C101			CK73GB1H102K	CHIP C 1000PF K	T3
D8			M1308	DIODE		C102			CK73GB1E103K	CHIP C 0.010UF K	
D9,10			MA716	DIODE		C103			CK73GB1H102K	CHIP C 1000PF K	T3
D11			DSA3A1	SURGE ABSORBER		C104			CC73GCH1H0R5C	CHIP C 0.5PF C	
D12			ERZ-M10DK220	SARGE ABSORBER		C105			CC73GCH1H220J	CHIP C 22PF J	T3
D13			1SS226	DIODE		C105			CC73GCH1H221J	CHIP C 220PF J	T,X,E9
IC1			KCD04	IC (FM/IF)		C106			CC73GCH1H120J	CHIP C 12PF J	T3
IC2			UPC1241H	IC (AF POWER AMP)		C106			CC73GCH1H221J	CHIP C 220PF J	T,X,E9
IC3			KCA05	IC (MIC AMP)		C107			CC73GCH1H0R5C	CHIP C 0.5PF C	T,X,E9
IC4			NJM78L05UA	IC (VOLTAGE REGULATOR/ +5V)		C108			CC73GCH1H040C	CHIP C 4.0PF C	T3
IC5			LA5010M	IC (LOW SATURATION REGULATOR)		C109			CC73GCH1H0R3B	CHIP C 0.3PF B	T,X,E9
IC6			KCB30	IC (DRIVE AMP /260MHz)		C110			CK73GB1E103K	CHIP C 0.010UF K	
IC7			L7808CV	IC (VOLTAGE REGULATOR/ +8V)		C111			CC73GCH1H0R5C	CHIP C 0.5PF C	T3
IC8			NJM2904E	IC (OP AMP X2)		C111			CC73GCH1H010C	CHIP C 1.0PF C	T,X,E9
Q1,2			3SK184(S)	FET		C112			CK73GB1E103K	CHIP C 0.010UF K	
Q3			2SC2714(Y)	TRANSISTOR		C113			CC73GCH1H020C	CHIP C 2.0PF C	
Q4			2SJ106(GR)	FET		C114			CK73GB1H102K	CHIP C 1000PF K	
Q5			2SD1757K	TRANSISTOR		C115			CC73GCH1H020C	CHIP C 2.0PF C	
Q6			2SA1362(Y)	TRANSISTOR		C116-120			CK73GB1H102K	CHIP C 1000PF K	
Q7			2SB1119(S)	TRANSISTOR		C121			CC73GCH1H220J	CHIP C 22PF J	
Q8			DTC144WK	DIGITAL TRANSISTOR		CN1			E40-5201-05	PIN CONNECTOR (7P)	
Q9			DTC114WK	DIGITAL TRANSISTOR		CN101			E40-0411-05	PIN CONNECTOR (4P)	
Q10,11			2SC4116(Y)	TRANSISTOR		CN102			E40-0311-05	PIN CONNECTOR (3P)	
Q12			DTC144EK	DIGITAL TRANSISTOR					F11-1122-24	SHIELDING CASE	
Q13			DTC114WK	DIGITAL TRANSISTOR							
Q14,15			2SD1757K	TRANSISTOR		L1			L92-0131-05	CORE	
Q16			2SC4116(Y)	TRANSISTOR		L2			L92-0131-05	CORE	T3
Q17			2SC2757(T33)	TRANSISTOR		L3			L92-0131-05	CORE	
Q18			2SD1406(Y)	TRANSISTOR		L4			L40-1081-80	SMALL FIXED INDUCTOR (100nH)	
Q19			2SB1302(S)	TRANSISTOR		L101			L40-1092-19	SMALL FIXED INDUCTOR (1UH)	
A1			X59-4100-50	HPF UNIT		L102,103			L40-4791-19	SMALL FIXED INDUCTOR (4.7UH)	
A2			X58-3980-21	PLL UNIT		L104-107			L33-1268-15	SMALL FIXED INDUCTOR (10UH)	
A3			X59-4090-50	APC UNIT		L108			L34-2332-05	COIL	
						L109			L34-2331-05	COIL	
						L110			L40-1581-80	SMALL FIXED INDUCTOR (150nH)	
PLL (X58-3970-XX) -50 : T3 -51 : T,X,E9						R1-3			RK73FB2A472J	CHIP R 4.7K J 1/10W	
C1-3			CK73FB1H102K	CHIP C 1000PF K		R4			RK73FB2A102J	CHIP R 1.0K J 1/10W	
C4			CK73FB1E104K	CHIP C 0.10UF K		R5			RK73FB2A222J	CHIP R 2.2K J 1/10W	
C5,6			CK73FB1H102K	CHIP C 1000PF K		R6,7			RK73FB2A471J	CHIP R 470 J 1/10W	
C7			CK73FB1E104K	CHIP C 0.10UF K	T3	R8			RK73FB2A152J	CHIP R 1.5K J 1/10W	T,X,E9
C8			CK73FB1H102K	CHIP C 1000PF K		R8			RK73FB2A471J	CHIP R 470 J 1/10W	T3
C9			CC73FCH1H100D	CHIP C 10PF D		R9			RK73FB2A222J	CHIP R 2.2K J 1/10W	T,X,E9
C10			CK73FB1H102K	CHIP C 1000PF K		R9			RK73FB2A472J	CHIP R 4.7K J 1/10W	T3
C11			CK73FB1E683K	CHIP C 0.068UF K		R10			RK73FB2A223J	CHIP R 22K J 1/10W	
C12			CK73FB1E104K	CHIP C 0.10UF K		R11			RK73FB2A103J	CHIP R 10K J 1/10W	
C13			CK73FB1H102K	CHIP C 1000PF K		R12			RK73FB2A222J	CHIP R 2.2K J 1/10W	
C14			CK73FB1E333K	CHIP C 0.033UF K	T3	R13			RK73FB2A221J	CHIP R 220 J 1/10W	
C14			CK73FB1E473K	CHIP C 0.047UF K	T,X,E9	R14			R92-0670-05	CHIP R 0 OHM	
C15			C92-0504-05	CHIP-TAN 0.68UF 20WV	T3	R15			RK73FB2A682J	CHIP R 6.8K J 1/10W	
C15			C92-0588-05	CHIP-TAN 1.5UF 16V	T,X,E9	R16			RK73FB2A221J	CHIP R 220 J 1/10W	
C16			CC73FCH1H030C	CHIP C 3.0PF C	T3	R101			RK73GB1J183J	CHIP R 18K J 1/16W	
C16			CC73FCH1H040C	CHIP C 4.0PF C	T,X,E9	R102			RK73GB1J470J	CHIP R 47 J 1/16W	
C17			C92-0504-05	CHIP-TAN 0.68UF 20WV	T3	R103,104			RK73GB1J101J	CHIP R 100 J 1/16W	
C17			C92-0588-05	CHIP-TAN 1.5UF 16V	T,X,E9	R105			RK73GB1J104J	CHIP R 100K J 1/16W	
						R106			R92-1252-05	CHIP R 0 OHM	T3

TK-715 : K,T,T3,X,E,E9

TK-715(N) : M

PARTS LSIT

PLL (X58-3970-XX)

PLL (X58-398X-XX)

Ref. No.	Address	New parts	Parts No.	Description	Destination
R107			RK73GB1J103J	CHIP R 10K J 1/16W	T3
R108,109			RK73GB1J470J	CHIP R 47 J 1/16W	
R110,111			RK73GB1J101J	CHIP R 100 J 1/16W	
R112,113			RK73GB1J471J	CHIP R 470 J 1/16W	
R114			RK73GB1J103J	CHIP R 10K J 1/16W	
R115			RK73GB1J472J	CHIP R 4.7K J 1/16W	
R116			RK73GB1J222J	CHIP R 2.2K J 1/16W	
R117			RK73GB1J471J	CHIP R 470 J 1/16W	
D101			1SV164	VARI-CAP DIODE	
D102			1SV166	VARI-CAP DIODE	T,X,E9
D102			1T33C	VARI-CAP DIODE	T3
D103			1SV166	VARI-CAP DIODE	
D104			1SV166	VARI-CAP DIODE	T,X,E9
D104			1T33C	VARI-CAP DIODE	T3
D105			1SV166	VARI-CAP DIODE	
D106,107			MA77	DIODE	T3
IC1			TC9181F	IC (PLL)	
IC2			MB504F	IC (MODULUS PRE SCALER)	
Q1			2SC4215(Y)	TRANSISTOR	
Q2			2SC2713(B)	TRANSISTOR	
Q3			2SC3324(B)	TRANSISTOR	
Q101			DTC114EU	DIGITAL TRANSISTOR	T3
Q102,103			2SK508NV(K52)	FET	
Q104			UMH5N	TRANSISTOR	
Q105			DTC114EU	DIGITAL TRANSISTOR	
Q106			2SC4083(P,Q)	TRANSISTOR	
PLL (X58-398X-XX) 0-11 : K 0-21 : M 2-71 : E					
C1-3			CK73FB1H102K	CHIP C 1000PF K	
C4			CK73FB1E104K	CHIP C 0.10UF K	
C5,6			CK73FB1H102K	CHIP C 1000PF K	
C7			CK73FB1E104K	CHIP C 0.10UF K	
C8			CK73FB1H102K	CHIP C 1000PF K	
C9			CC73GCH1H050C	CHIP C 5.0PF C	
C11			CK73FB1E473K	CHIP C 0.047UF K	
C12			CK73FB1E104K	CHIP C 0.10UF K	
C13			CK73FB1H102K	CHIP C 1000PF K	
C14			CK73FB1E393K	CHIP C 0.039UF K	E,M
C14			CK73FB1E473K	CHIP C 0.047UF K	K
C15			C92-0588-05	CHIP-TAN 1.5UF 16WV	E,M
C15			C92-0504-05	CHIP-TAN 0.68UF 20WV	K
C16			CC73FCH1H020C	CHIP C 2.0PF C	
C17			C92-0512-05	CHIP-TAN 1.0UF 16WV	
C18,19			CK73FB1H102K	CHIP C 1000PF K	
C20			C92-0555-05	CHIP-TAN 0.047UF 35WV	E,M
C20			C92-0503-05	CHIP-TAN 0.068UF 35WV	K
C101			CK73GB1H102K	CHIP C 1000PF K	
C102,103			CK73GB1H471K	CHIP C 470PF K	
C104			CK73GB1H102K	CHIP C 1000PF K	
C105			CC73GCH1H150J	CHIP C 15PF J	M
C105			CC73GCH1H180J	CHIP C 18PF J	K
C105,106			CC73GCH1H080D	CHIP C 8.0PF D	E
C106			CC73GCH1H120J	CHIP C 12PF J	M
C106			CC73GCH1H090D	CHIP C 9.0PF D	K
C107			CC73GCH1H010C	CHIP C 1.0PF C	
C108,109			CC73GCH1H060D	CHIP C 6.0PF D	E
C108,109			CC73GCH1H070D	CHIP C 7.0PF D	M,K

Ref. No.	Address	New parts	Parts No.	Description	Destination
C110			CK73GB1H102K	CHIP C 1000PF K	
C111			CC73GCH1H030C	CHIP C 3.0PF C	E
C111			CC73GCH1H050C	CHIP C 5.0PF C	M,K
C112			CC73GCH1H050C	CHIP C 5.0PF C	
C113			CC73GCH1H010C	CHIP C 1.0PF C	
C114			CC73GCH1H070D	CHIP C 7.0PF D	
C115			CC73GCH1H050C	CHIP C 5.0PF C	M
C115			CC73GCH1H060D	CHIP C 6.0PF D	E,K
C116			CC73GCH1H120J	CHIP C 12PF J	M
C116			CC73GCH1H150J	CHIP C 15PF J	E,K
C117			CC73GCH1H150J	CHIP C 15PF J	M
C117			CC73GCH1H180J	CHIP C 18PF J	E,K
C118			CC73GCH1H180J	CHIP C 18PF J	
C119			CC73GCH1H120J	CHIP C 12PF J	M
C119			CC73GCH1H180J	CHIP C 18PF J	E,K
C120,121			CK73GB1H102K	CHIP C 1000PF K	
C122			CC73GCH1H0R5C	CHIP C 0.5PF C	
C123,124			CK73GB1H102K	CHIP C 1000PF K	
C125			CC73GCH1H0R5C	CHIP C 0.5PF C	
C126			CC73GCH1H060D	CHIP C 6.0PF D	
C127			CK73GB1H102K	CHIP C 1000PF K	
CN1			E40-5201-05	PIN CONNECTOR (7P)	
CN101			E40-0411-05	PIN CONNECTOR (4P)	
CN102			E40-0311-05	PIN CONNECTOR (3P)	
-			F11-1122-24	SHIELDING CASE	
L1			L92-0131-05	CORE	
L3			L92-0131-05	CORE	
L4			L40-1081-80	SMALL FIXED INDUCTOR (100nH)	E,K
L4			L40-8272-80	SMALL FIXED INDUCTOR (82nH)	M
L101			L33-1268-15	SMALL FIXED INDUCTOR (10UH)	E,K
L101-104			L40-1892-19	SMALL FIXED INDUCTOR (1.8UH)	M
L102			L33-1268-15	SMALL FIXED INDUCTOR (10UH)	E,K
L103,104			L40-2292-19	SMALL FIXED INDUCTOR (2.2UH)	E,K
L105			L40-2281-80	SMALL FIXED INDUCTOR (220NH)	
L106			L34-4387-05	COIL	M
L106			L34-4452-05	COIL	E,K
L107			L34-4387-05	COIL	M
L107			L34-4453-05	COIL	E,K
L108			L40-2281-80	SMALL FIXED INDUCTOR (220NH)	
L109,110			L40-8282-19	SMALL FIXED INDUCTOR (0.82UH)	
L111			L40-6872-80	SMALL FIXED INDUCTOR (68NH)	M
L111			L40-8272-80	SMALL FIXED INDUCTOR (82NH)	E,K
R1-3			RK73FB2A472J	CHIP R 4.7K J 1/10W	
R4			RK73FB2A102J	CHIP R 1.0K J 1/10W	
R5			RK73FB2A222J	CHIP R 2.2K J 1/10W	
R6			RK73FB2A471J	CHIP R 470 J 1/10W	E
R6			RK73FB2A152J	CHIP R 1.5K J 1/10W	K
R6			R92-0670-05	CHIP R 0 OHM	M
R7			R92-0670-05	CHIP R 0 OHM	
R8			RK73FB2A102J	CHIP R 1.0K J 1/10W	K
R8,9			RK73FB2A272J	CHIP R 2.7K J 1/10W	M
R8,9			RK73FB2A332J	CHIP R 3.3K J 1/10W	E
R9			RK73FB2A392J	CHIP R 3.9K J 1/10W	K
R10			RK73FB2A472J	CHIP R 4.7K J 1/10W	
R11			RK73FB2A222J	CHIP R 2.2K J 1/10W	
R12			RK73FB2A102J	CHIP R 1.0K J 1/10W	E
R12			RK73FB2A152J	CHIP R 1.5K J 1/10W	M,K

TK-715 : K,T,T3,X,E,E9

TK-715(N) : M

PARTS LIST

PLL (X58-398X-XX)

APC (X59-4090-50)

HPF (X59-4100-XX)

Ref. No.	Address	New parts	Parts No.	Description	Destination	Ref. No.	Address	New parts	Parts No.	Description	Destination
R13			RK73FB2A331J	CHIP R 330 J 1/10W		C4-6			CK73FB1H272K	CHIP C 2700PF K	X,M,E9
R14			R92-0670-05	CHIP R 0 OHM		C7			CK73FB1H102K	CHIP C 1000PF K	
R15			RK73FB2A392J	CHIP R 3.9K J 1/10W	E	C8	*		CC73FCH1H272J	CHIP C 2700PF J	K
R15			RK73FB2A472J	CHIP R 4.7K J 1/10W	M	C8			CK73FB1H272K	CHIP C 2700PF K	T,T3,E
R15			RK73FB2A332J	CHIP R 3.3K J 1/10W	K	C8			CK73FB1H272K	CHIP C 2700PF K	X,M,E9
R16			RK73FB2A221J	CHIP R 220 J 1/10W		C10			CK73EF1C105Z	CHIP C 1.0UF Z	
R101,102			RK73GB1J221J	CHIP R 220 J 1/16W					E23-0471-05	TERMINAL	
R103			RK73GB1J102J	CHIP R 1.0K J 1/16W		R1			RK73GB1J394J	CHIP R 390K J 1/16W	
R104			RK73GB1J683J	CHIP R 68K J 1/16W		R2			RK73GB1J681J	CHIP R 680 J 1/16W	
R105,106			RK73GB1J470J	CHIP R 47 J 1/16W		R3			RK73GB1J332J	CHIP R 3.3K J 1/16W	
R107			RK73GB1J181J	CHIP R 180 J 1/16W		R4			RK73GB1J124J	CHIP R 120K J 1/16W	T,T3,E
R108			RK73GB1J221J	CHIP R 220 J 1/16W		R4			RK73GB1J124J	CHIP R 120K J 1/16W	X,M,E9
R109,110			RK73GB1J470J	CHIP R 47 J 1/16W		R5			RK73GB1J683J	CHIP R 68K J 1/16W	T,T3,E
R111			RK73GB1J103J	CHIP R 10K J 1/16W		R5			RK73GB1J683J	CHIP R 68K J 1/16W	X,M,E9
R112			RK73GB1J392J	CHIP R 3.9K J 1/16W		R5			RK73GB1J123J	CHIP R 12K J 1/16W	K
R113			RK73GB1J101J	CHIP R 100 J 1/16W		R6-7			RK73GB1J824J	CHIP R 820K J 1/16W	
R114			RK73GB1J103J	CHIP R 10K J 1/16W		R8			RK73FB2A124G	CHIP R 120K G 1/10W	T,T3,E
D101			1T363A	DIODE		R8			RK73FB2A124G	CHIP R 120K G 1/10W	X,M,E9
D102			1S164	DIODE		R8			RN73FH2A224D	CHIP R 220K D 1/16W	K
D103-105			1T363A	DIODE		R9			RK73FB2A564G	CHIP R 560K G 1/10W	T,T3,E
IC1			TC9181F	IC (PLL)		R9			RK73FB2A564G	CHIP R 560K G 1/10W	X,M,E9
IC2			MB504F	IC (MODULUS PRE SCALER)		R9			RN73FH2A474D	CHIP R 470K D 1/16W	K
Q1			2SC4215(Y)	TRANSISTOR		R10			RK73FB2A104G	CHIP R 100K G 1/10W	T,T3,E
Q2,3			2SC3722K(S)	TRANSISTOR		R10			RK73FB2A104G	CHIP R 100K G 1/10W	X,M,E9
Q101,102			2SK508NV(K52)	FET		R10			RN73FH2A104D	CHIP R 100K D 1/16W	K
Q103			DTC114EU	DIGITAL TRANSISTOR		R16			RK73GB1J122J	CHIP R 1.2K J 1/16W	
Q104			UMH5N	DIGITAL TRANSISTOR		R17			R92-0670-05	CHIP R 0 OHM	
Q105			2SC3120	TRANSISTOR		IC1			NJM4558M	IC (OP AMP X2)	
						Q1			2SC2712(Y)	TRANSISTOR	
APC (X59-4090-50)											
C1			CK73FB1H102K	CHIP C 1000PF K							
C2			C92-0501-05	CHIP-TAN 1.5UF 10WV							
C3			CK73FB1H472K	CHIP C 4700PF K							
C4			CK73FB1H102K	CHIP C 1000PF K							
C5			CK73FB1H472K	CHIP C 4700PF K							
C6			CK73FB1H102K	CHIP C 1000PF K							
			E23-0471-05	TERMINAL							
R1			RK73FB2A222J	CHIP R 2.2K J 1/10W							
R2			RK73FB2A102J	CHIP R 1.0K J 1/10W							
R3			RK73FB2A152J	CHIP R 1.5K J 1/10W							
R4,5			RK73FB2A103J	CHIP R 10K J 1/10W							
R6			RK73FB2A122J	CHIP R 1.2K J 1/10W							
Q1,2			FMW1	DIGITAL TRANSISTOR							
Q3			2SA1162(Y)	TRANSISTOR							
HPF (X59-4100-XX) -50 : T,T3,X,E,E9,M -52 : K											
C1			CK73GB1E223K	CHIP C 0.022UF C	K						
C2			CK73GB1H682K	CHIP C 6800PF K	K						
C1-3			CK73GB1H272K	CHIP C 2700PF K	T,T3,E						
C1-3			CK73GB1H272K	CHIP C 2700PF K	X,M,E9						
C3			CK73GB1E123K	CHIP C 0.012UF K	K						
C4-6		*	CC73FCH1H272J	CHIP C 2700PF J	K						
C4-6			CK73FB1H272K	CHIP C 2700PF K	T,T3,E						

TK-715 : K,T,T3,X,E,E9

TK-715(N) : M

TK-715/(N)

EXPLODED VIEW (TK-715 : K,T,T3,X,E,E9)

- | | | | |
|---|-------------------|---|-------------|
| B | M3 x 3 | : | N67-3008-46 |
| C | M4 x 8 | : | N09-2230-05 |
| D | M2.6 x 6 (OC) BLK | : | N33-2606-45 |
| E | M2.6 x 4 | : | N38-2640-46 |
| F | M2.6 x 6 (Br-Tap) | : | N87-2606-46 |
| G | M2.6 x 6 (F-TaP) | : | N88-2606-46 |

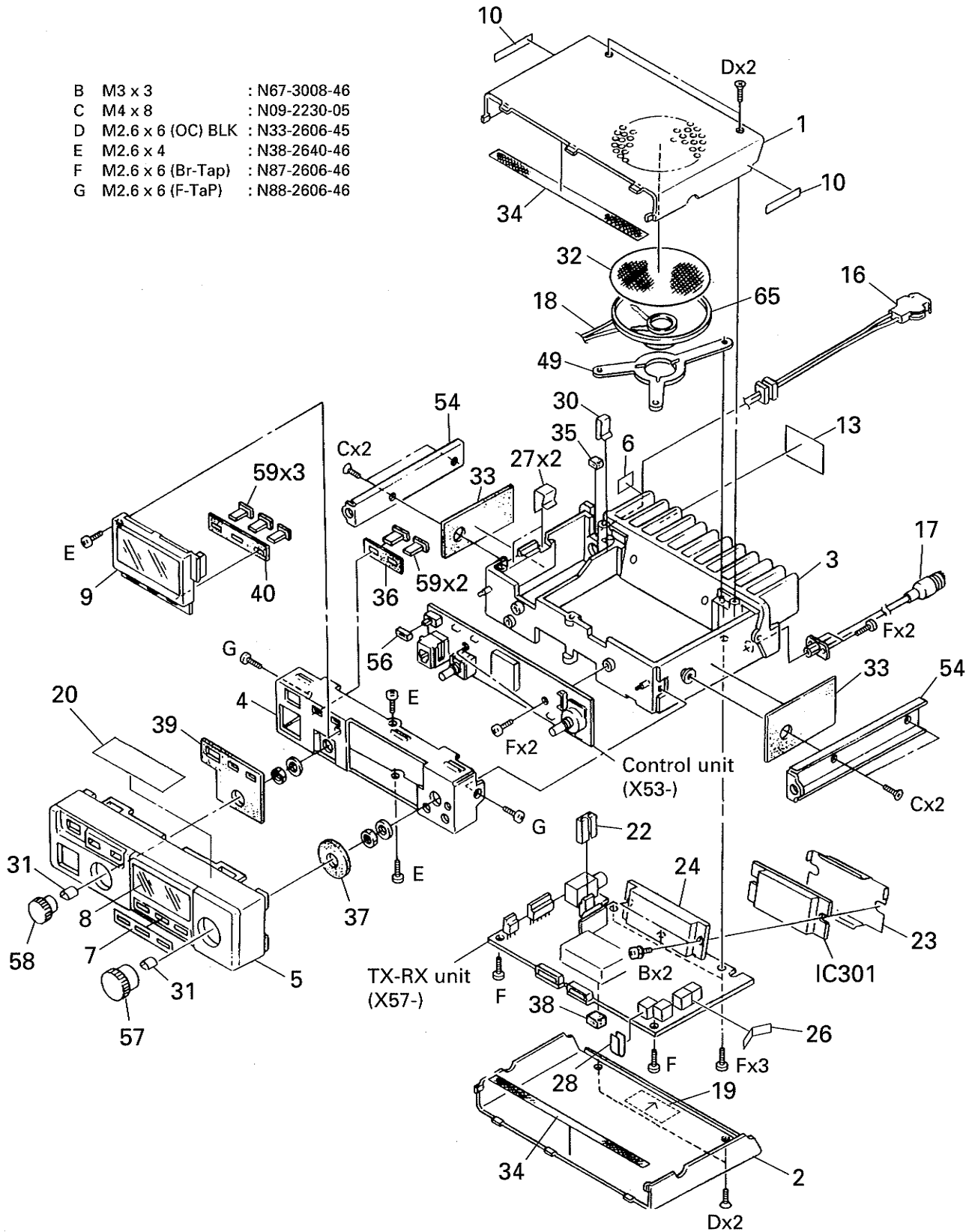

EXPLODED VIEW (TK-715(N) : M)

- | | | | |
|---|-------------------|---|-------------|
| B | M3 x 3 | : | N67-3008-46 |
| C | M4 x 8 | : | N09-2230-05 |
| D | M2.6 x 6 (OC) BLK | : | N33-2606-45 |
| E | M2.6 x 4 | : | N38-2640-46 |
| F | M2.6 x 6 (Br-Tap) | : | N87-2606-46 |
| G | M2.6 x 6 (F-TaP) | : | N88-2606-46 |

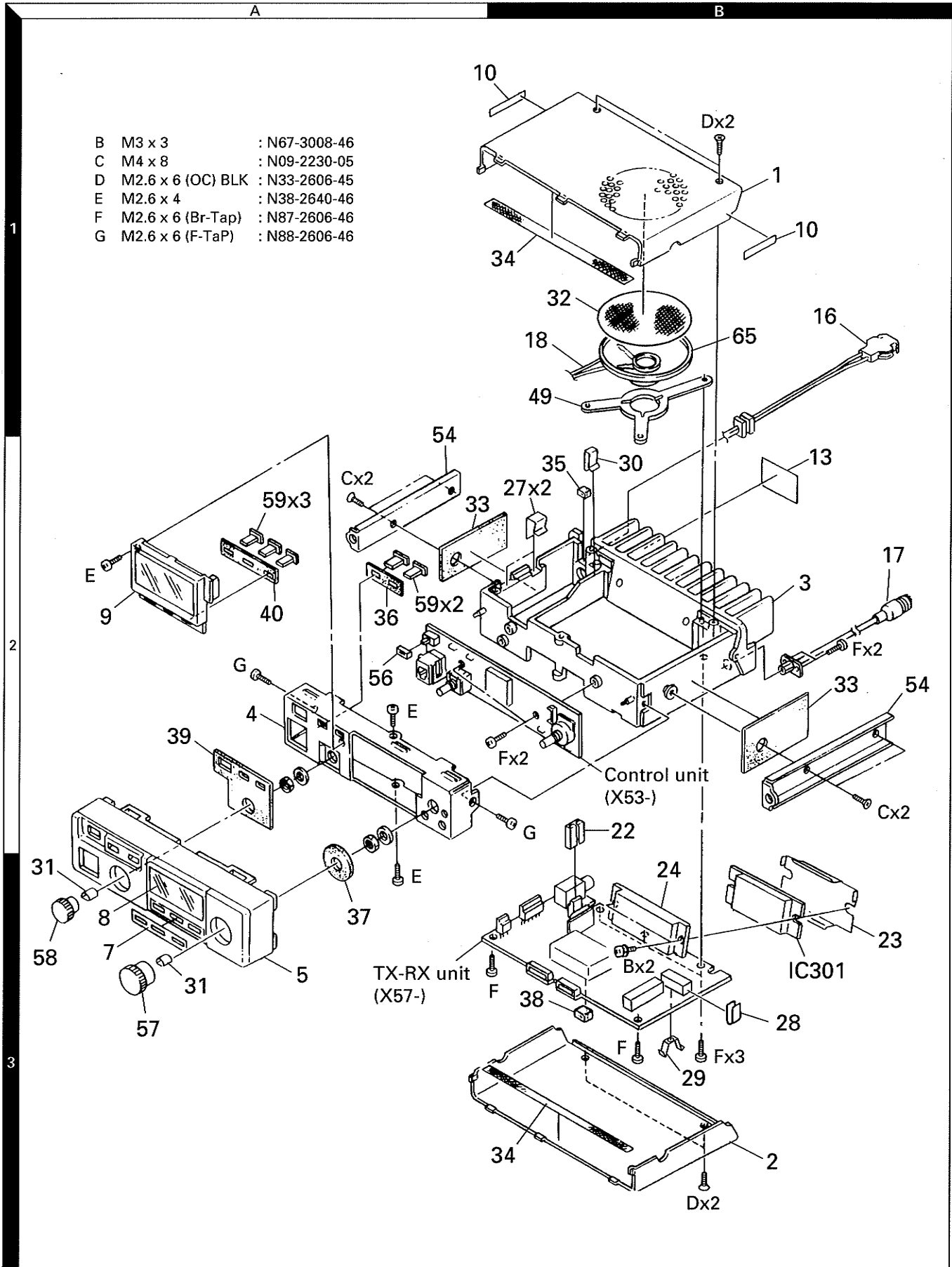

PACKING

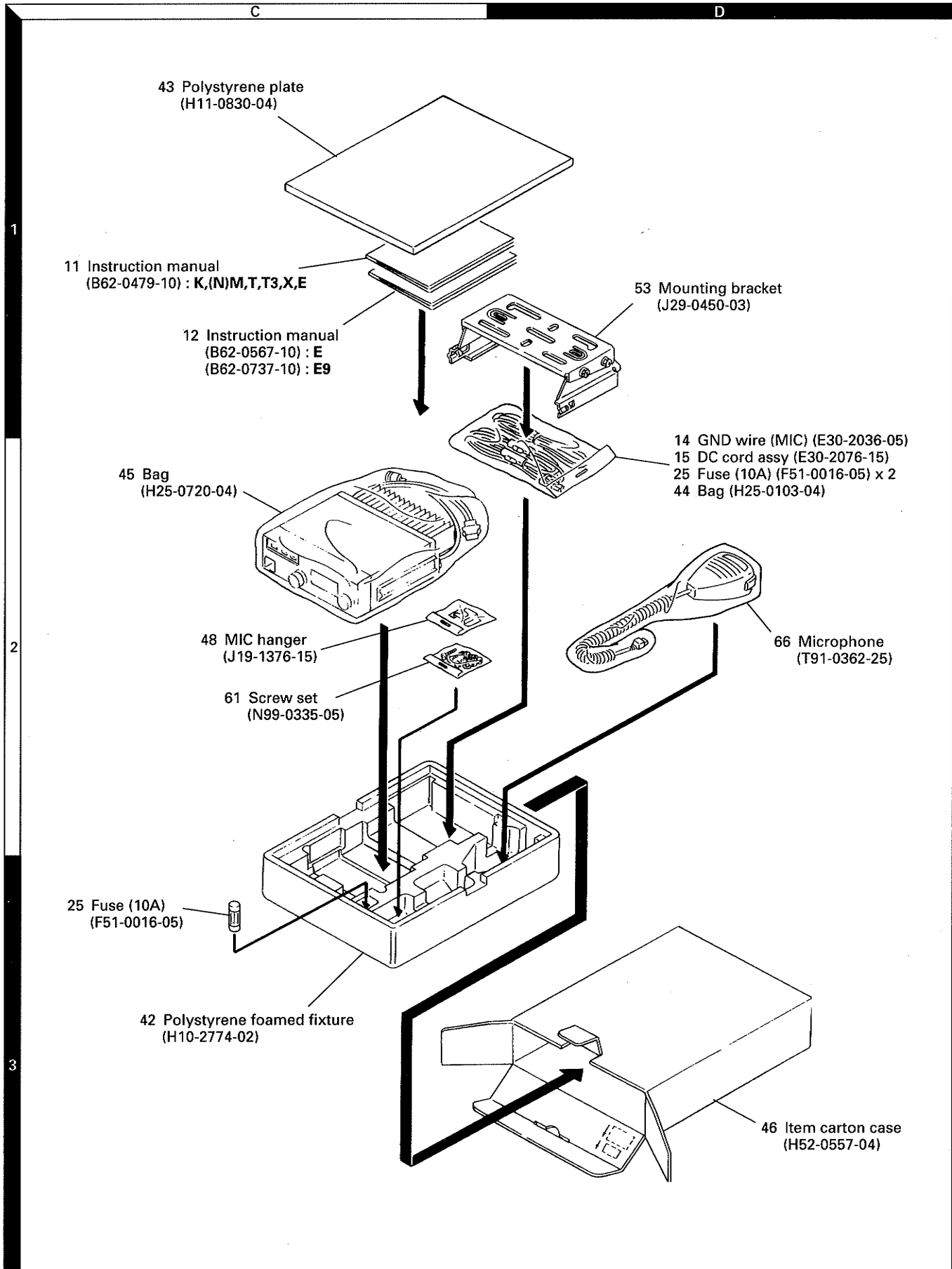

ADJUSTMENT

Test Equipment Required for Alignment

No.	Test Equipment	Major Specifications
1	Standard Signal Generator (SSG)	Frequency Range: 100 to 500MHz. Modulation: Frequency modulation and external modulation. Output: 0.1μV to greater than 1mV.
2	Power Meter	Input Impedance: 50Ω. Operation Frequency: 100 to 500MHz or more. Measurement Capability: Vicinity of 60W.
3	Deviation Meter	Frequency Range: 100 to 500MHz.
4	Digital Volt Meter (DVM)	Measuring Range: 1 to 30V DC. Accuracy: High input impedance for minimum circuit loading.
5	Oscilloscope	DC through 30MHz.
6	High Sensitivity Frequency Counter	Frequency Range: 10Hz to 500MHz. Frequency Stability: 0.2ppm or less.
7	Ammeter	15A.
8	AF Volt Meter (AF VTVM)	Frequency Range: 50Hz to 10kHz. Voltage Range: 3mV to 3V.
9	Audio Generator (AG)	Frequency Range: 50Hz to 5kHz or more. Output: 0 to 1V.
10	Distortion Meter	Capability: 3% or less at 1kHz. Input Level: 50mV to 10Vrms.
11	Voltmeter	Measuring Range: 1.5 to 30V DC or less. Input Impedance: 50kΩ/V or greater.
12	4Ω Dummy Load	Approx. 4Ω, 3W.
13	Regulated Power Supply	13.6V, approx. 15A (adjustable from 9 to 17V). Useful if ammeter equipped.
14	Tracking Generator	

Type	RX freq' fr() MHz			TX freq' fr() MHz		
	L	M	H	L	M	H
T3	SUB1	177.2125	192.3500	183.4875	185.2125	191.4875
	SUB2	201.2125		207.4875	193.2125	199.4875
T,E9	150.0500	162.0500	173.9500	150.0000	162.0000	173.9875
X	162.0625	165.1000	168.2000	157.4625	165.1000	172.8000
E	229.0000	229.7500	230.4750	223.0000	223.7500	224.4750
(N)M	254.0000	256.7000	259.3875	262.0000	264.7500	267.3875
K	217.0125	217.5000	217.9875	219.0125	219.5000	219.9875

L : Low freq'
M : Mid freq'
H : High freq'

- The following test cables are recommended

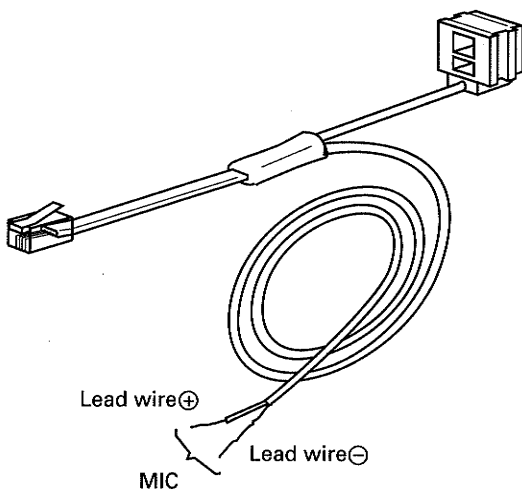

Tuning cable (E30-3217-05)

MIC connector front view

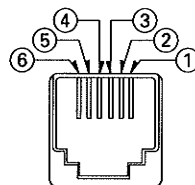

- ① SB
- ② PTTG
- ③ PTT
- ④ MICG
- ⑤ MIC
- ⑥ HOOK

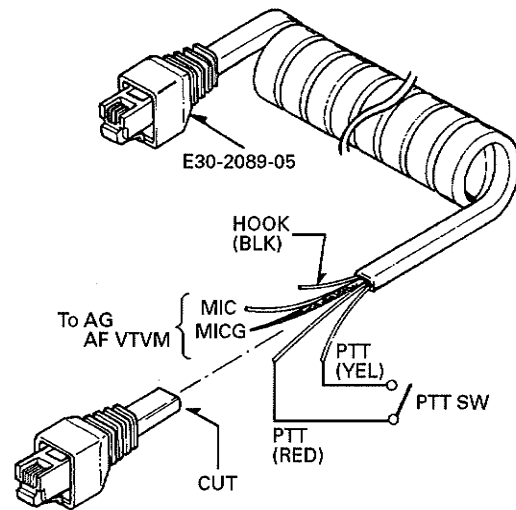

Test cable for Microphone input

TK-715/(N)

ADJUSTMENT (TK-715 : K,T,T3,X,E,E9)

Common Section Adjustment

Item	Condition	Measurement			Adjustment			Specifications/Remarks		
		Test-equipment	Unit	Terminal	Unit	Parts	Method			
1. Setting	1) Write in freq' and signaling data with EEPROM writer. Source voltage : DC 13.6V POWER SW : OFF VOL VR : Full counterclockwise (CCW). TX-RX unit VR3~5 : Center VR2 : CW VR1, 6 : CCW CN4 (J2) : SET side									
2. PLL	RX	1) Frequency : f _{RL}	DVM	TX-RX	TP2			Check	1.5V or more.	
		2) Frequency : f _{RH}							9.0V or less.	
	TX	3) Frequency : f _{TL} PTT : ON	Dummy	Rear panel	ANT					1.5V or more.
		4) Frequency : f _{TH} PTT : ON								9.0V or less.
3. Transmit frequency adjustment	1) Frequency : f _{TH} PTT : ON	f. counter Power meter	Rear panel	ANT			Check	f ± 500Hz T,T3,X,E9 f ± 600Hz K,E		

Receiver Section Adjustment

Item	Condition	Measurement			Adjustment			Specifications/Remarks
		Test-equipment	Unit	Terminal	Unit	Parts	Method	
1. BPF	1) Frequency : f _{RL} SSG output : 0.5μV/-113dBm MOD : 1kHz DEV : ±1.5kHz	DC V.M SSG	TX-RX Rear panel	TP1 ANT	TX-RX	L1~4	Repeat for MAX.	
2. MCF	1) Frequency : f _{RL} SSG output : 0.5μV/-113dBm MOD : 1kHz DEV : ±1.5kHz				TX-RX	L6	T3 Adjust for MAX. T,X,E9 Adjust for MIN. K,E Turn one the core of L6 counterclockwise from maximum level.	
3. Receiving sensitivity	1) Frequency : f _{RL} and f _{RH} SSG output : 0.3μV/-118dBm MOD : 1kHz DEV : ±1.5kHz	AF V.M Oscilloscope	Rear panel	EXT. SP			Check	SINAD 12dB or more.
		SSG		ANT				
4. Squelch	1) Frequency : f _{RL} SSG output : Turn the SSG output 4dB down so that the SINAD sensitivity becomes 12dB.				TX-RX	VR2	Set to the point at which squelch just close.	
	2) SSG output : Sensitivity value of 12dB SINAD.						Check	Squelch should open.
	3) SSG output : OFF							Squelch should close.

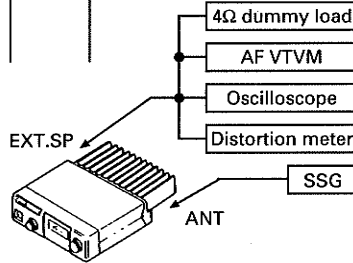

ADJUSTMENT (TK-715 : K,T,T3,X,E,E9)

Item	Condition	Measurement			Adjustment			Specifications/Remarks
		Test-equipment	Unit	Terminal	Unit	Parts	Method	
5. Acquisition threshold	1) Frequency : f _{RL} SSG output : 10μV/-87dBm	LCD					Check	LCD display "0"
	2) SSG output : 1μV/-107dBm 2μV/-95dBm E	SSG	Rear panel	ANT	TX-RX	VR1	Adjust for LCD display "2".	
	3) SSG output : 0.3μV/-117dBm						Check	LCD display "0"

Transmitter Section Adjustment

Item	Condition	Measurement			Adjustment			Specifications/Remarks
		Test-equipment	Unit	Terminal	Unit	Parts	Method	
1. APC	1) Frequency : f _{TM} PTT : ON	Power meter Ammeter	Rear panel	ANT			MAX	28W or more.
					TX-RX	VR6	25W T,T3,X,E9 15W E 10W K	±1W, 7.0A or less. T,T3,X,E9 ±0.5W, 5.0A or less. K,E
	2) Frequency : f _{TL} and f _{TH} PTT : ON						Check	20~30W, 7.0A or less. T,T3,X,E9 12~18W, 5.0A or less. E 8~12W, 5.0A or less. K
2. Maximum deviation adjustment	1) Frequency : f _{TH} AG : 1kHz/50mV Deviation meter filter HPF : OFF LPF : 15kHz De-emphasis : OFF PTT : ON	Power meter Deviation meter Oscilloscope	Rear panel	ANT	TX-RX	VR5	±2.2kHz T3 ±2.1kHz T,X,E,E9	±100Hz
			Front panel	MIC				
3. MIC sensitivity adjustment	1) AG : 1kHz/5mV PTT : ON					VR4	±1.5kHz	±100Hz
4. FSK	1) Frequency : f _{TH} AG : OFF Deviation meter filter HPF : OFF LPF : 15kHz CALL key + PTT : ON					VR3	±1.5kHz	±200Hz
		LCD					Check	LCD display "101010"
5. Protection	1) Frequency : f _{TM} and f _{TH} ANT : Open PTT : ON	Ammeter					Check	7.0A or less. T,T3,X,E9 5.0A or less. K,E

Adjustment Points (Top View)

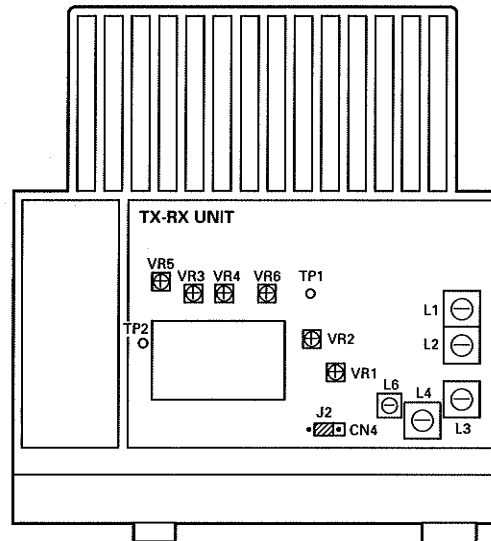

- L1~4 : BPF
- L6 : MCF
- VR1 : Acquisition threshold
- VR2 : Squelch
- VR3 : FSK
- VR4 : MIC sensitivity
- VR5 : Maximum deviation
- VR6 : APC

ADJUSTMENT (TK-715(N) : M)

Common Section Adjustment

Item	Condition	Measurement			Adjustment			Specifications/Remarks	
		Test-equipment	Unit	Terminal	Unit	Parts	Method		
1. Setting	1) Write in freq' and signaling data with EEPROM writer. Source voltage : DC 13.6V POWER SW : OFF VOL VR : Full counterclockwise (CCW). TX-RX unit VR3~5 : Center VR1 : CW VR2, 6 : CCW CN4 (J2) : SET side								
2. PLL	RX	1) Frequency : f _{RL}	DVM	TX-RX	TP3		Check	0.8V or more.	
		2) Frequency : f _{RH}						8.5V or less.	
	TX	3) Frequency : f _{TL} PTT : ON	Dummy	Rear panel	ANT			Check	0.8V or more.
		4) Frequency : f _{TH} PTT : ON							8.5V or less.
3. Transmit frequency adjustment	1) Frequency : f _{TH} PTT : ON	f. counter Power meter	Rear panel	ANT			Check	f ± 600Hz	

Receiver Section Adjustment

Item	Condition	Measurement			Adjustment			Specifications/Remarks
		Test-equipment	Unit	Terminal	Unit	Parts	Method	
1. Helical	1) Connect the tracking generator to ANT. Tracking generator output : -25dBm Connect the spectrum analyzer to TP1.	Tracking generator Spectrum analyzer	Rear panel TX-RX	ANT TP1	TX-RX	L1, 4 TC1	Check whether required band obtained at maximum gain.	
2. MCF	1) Frequency : f _{RM} SSG output : 0.5μV/-113dBm MOD : 1kHz DEV : ±1.5kHz	DC V.M SSG	TX-RX Rear panel	TP2 ANT	TX-RX	L7	Insert the core at the depth.	
3. Receiving sensitivity	1) Frequency : f _{RL} and f _{RH} SSG output : 0.3μV/-118dBm MOD : 1kHz DEV : ±1.5kHz	AF V.M Oscilloscope SSG	Rear panel	EXT. SP ANT			Check	SINAD 12dB or more.
4. Squelch	1) Frequency : f _{RM} SSG output : Turn the SSG output 4dB down so that the SINAD sensitivity becomes 12dB.	SSG	Rear panel	ANT	TX-RX	VR1	Set to the point at which squelch just close.	

ADJUSTMENT (TK-715(N) : M)

Item	Condition	Measurement			Adjustment			Specifications/Remarks
		Test-equipment	Unit	Terminal	Unit	Parts	Method	
	2) SSG output : Sensitivity value of 12dB SINAD.	SSG	Rear panel	ANT			Check	Squelch should open.
	3) SSG output : OFF							
5. Acquisition threshold	1) Frequency : f _{FM} SSG output : 10μV/-87dBm	LCD					Check	LCD display "0"
	2) SSG output : 1μV/-107dBm	SSG	Rear panel	ANT	TX-RX	VR2	Adjust for LCD display "2".	
	3) SSG output : 0.3μV/-117dBm						Check	LCD display "0"

Transmitter Section Adjustment

Item	Condition	Measurement			Adjustment			Specifications/Remarks
		Test-equipment	Unit	Terminal	Unit	Parts	Method	
1. APC	1) Frequency : f _{FM} PTT : ON	Power meter Ammeter	Rear panel	ANT			MAX	28W or more.
					TX-RX	VR6	25W	±1W 7.0A or less.
	2) Frequency : f _{TL} and f _{TH} PTT : ON						Check	20~30W 7.0A or less.
2. Maximum deviation adjustment	1) Frequency : f _{FM} AG : 1kHz/50mV Deviation meter filter HPF : OFF LPF : 15kHz De-emphasis : OFF PTT : ON	Power meter Deviation meter Oscilloscope	Rear panel	ANT	TX-RX	VR5	±2.1KHz	±100Hz
3. MIC sensitivity adjustment	1) AG : 1kHz/5mV PTT : ON	AG	Front panel	MIC		VR3	±1.5kHz	±100Hz
4. FSK	1) Frequency : f _{TH} AG : OFF Deviation meter filter HPF : OFF LPF : 15kHz CALL key + PTT : ON	LCD				VR4	±1.5kHz	±200Hz
							Check	LCD display "10101010"
5. Protection	1) Frequency : f _{FM} and f _{TH} ANT : Open PTT : ON	Ammeter					Check	7.0A or less.

Adjustment Points (Top View)

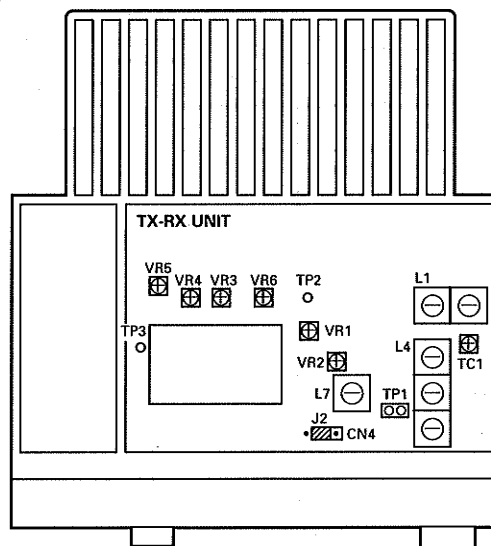

- L1,4 : Helical
- L7 : MCF
- TC1 : Helical
- VR1 : Squelch
- VR2 : Acquisition threshold
- VR3 : MIC sensitivity
- VR4 : FSK
- VR5 : Maximum deviation
- VR6 : APC

TK-715/(N) CIRCUIT DIAGRAM (TK-715 : T,T3,X,E9)

PLL (X58-3970-XX) -50 : TK-715 (T3) -51 : TK-715 (T,X,E9)

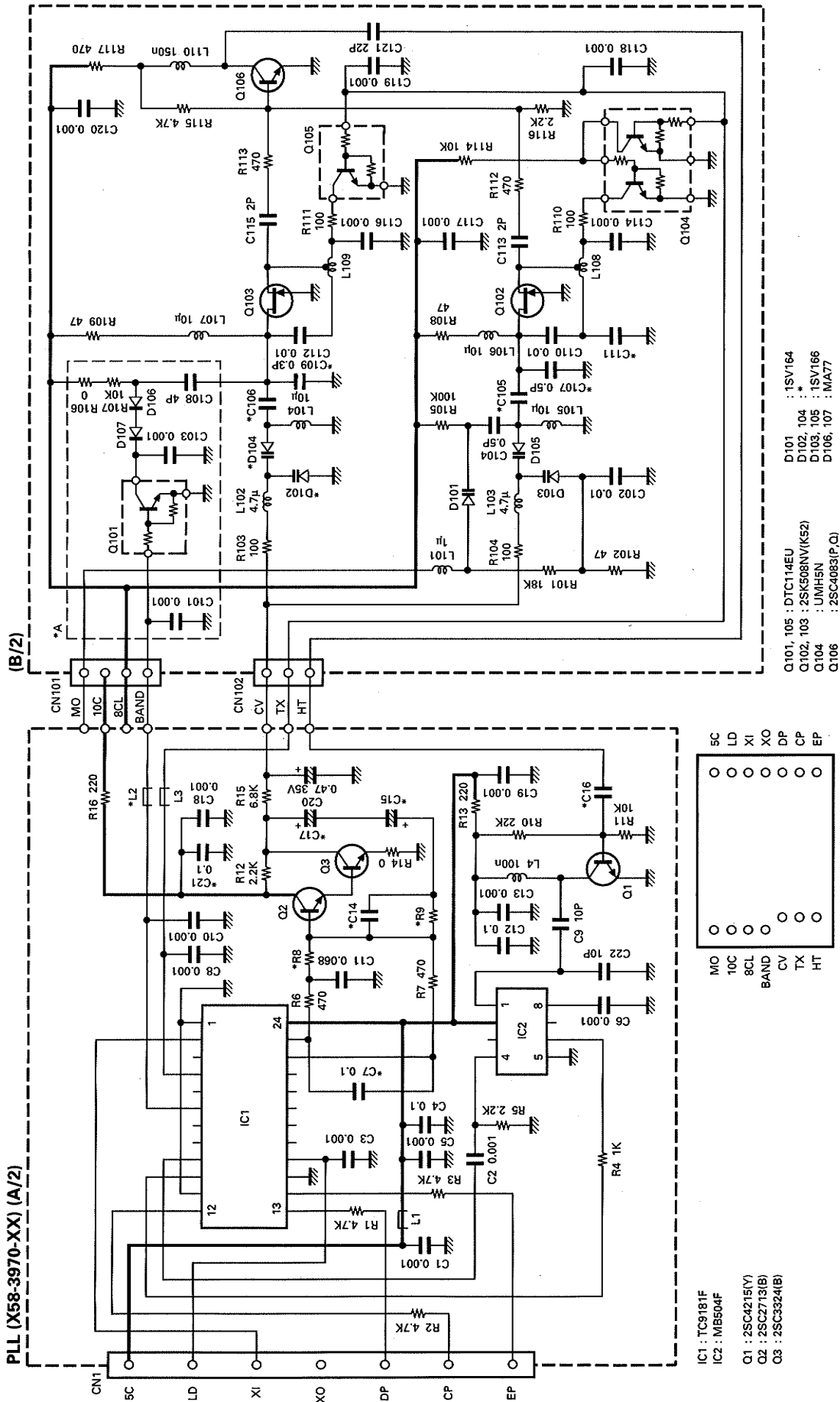

TOP VIEW

*A	D102,104	C7	C14	C15,17	C16	C21	C105	C106	C107	C109	C111	R8	R9	L2
0-50	YES	1T33C	YES	0.033	0.68 20V	3P	NO	22P	NO	NO	0.5P	470	4.7K	YES
0-51	NO	1SV166	NO	0.047	1.5 16V	4P	YES	220P	YES	1P	1.5K	2.2K	NO	NO

PC BOARD VIEWS (TK-715 : T,T3,X,E9)

TK-715/(N)

PLL (X58-3970-XX) (A/2) Component side view

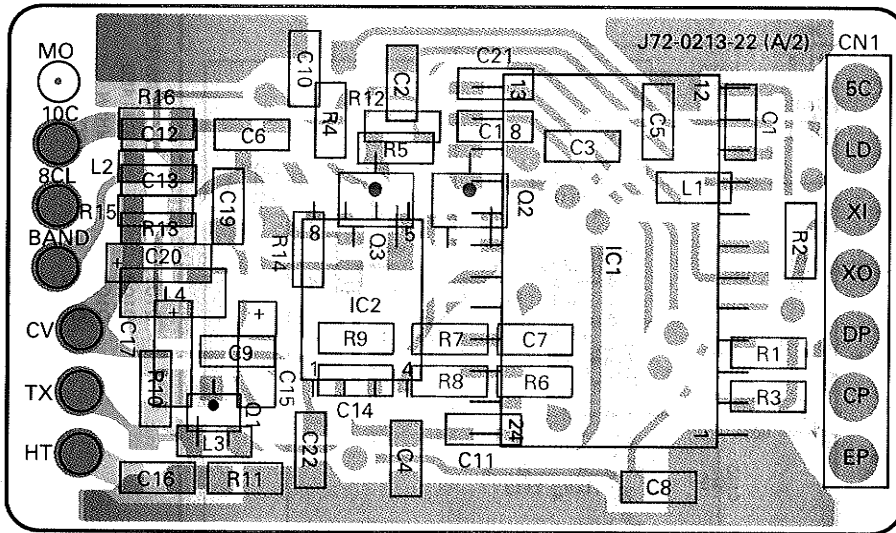

- 2SC2713
- 2SC3324
- 2SC4083
- 2SC4215
- DTC114EU



- 2SK508NV



- UMH5N

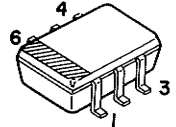

PLL (X58-3970-XX) (A/2) Foil side view

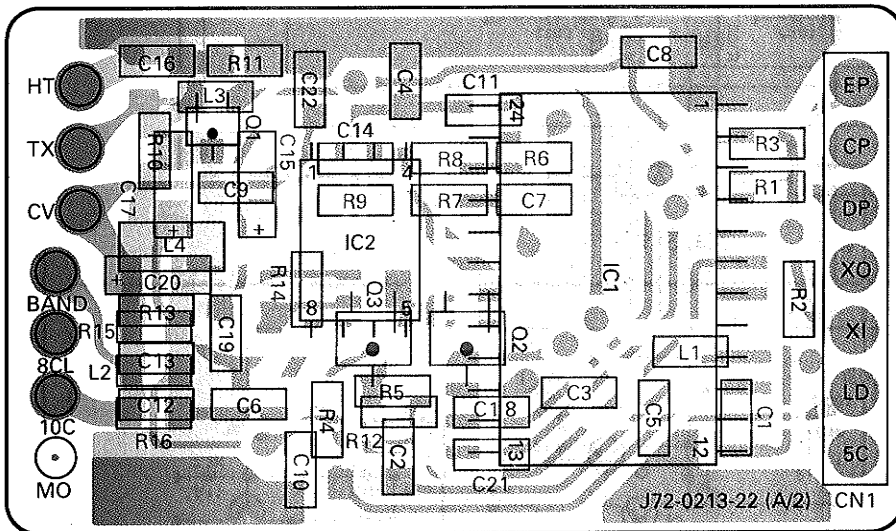

- MB504F

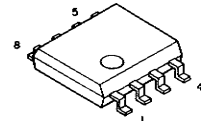

- TC9181F

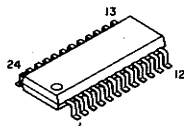

PLL (X58-3970-XX) (B/2) Component side view

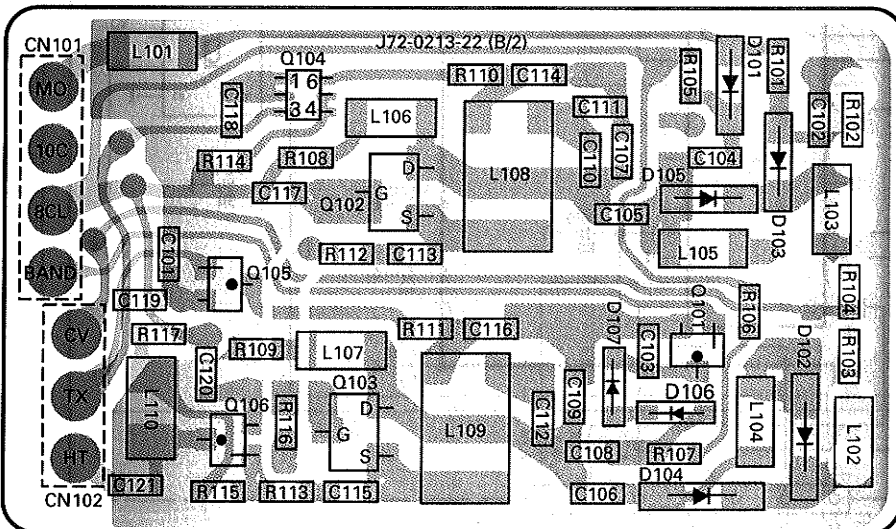

- Component side
- Foil side

TK-715/(N) CIRCUIT DIAGRAM (TK-715 : K,E TK-715(N) : M)

PLL (X58-398X-XX) 0-11 : TK-715 (K) 0-21 : TK-715(N) (M) 2-71 : TK-715 (E)

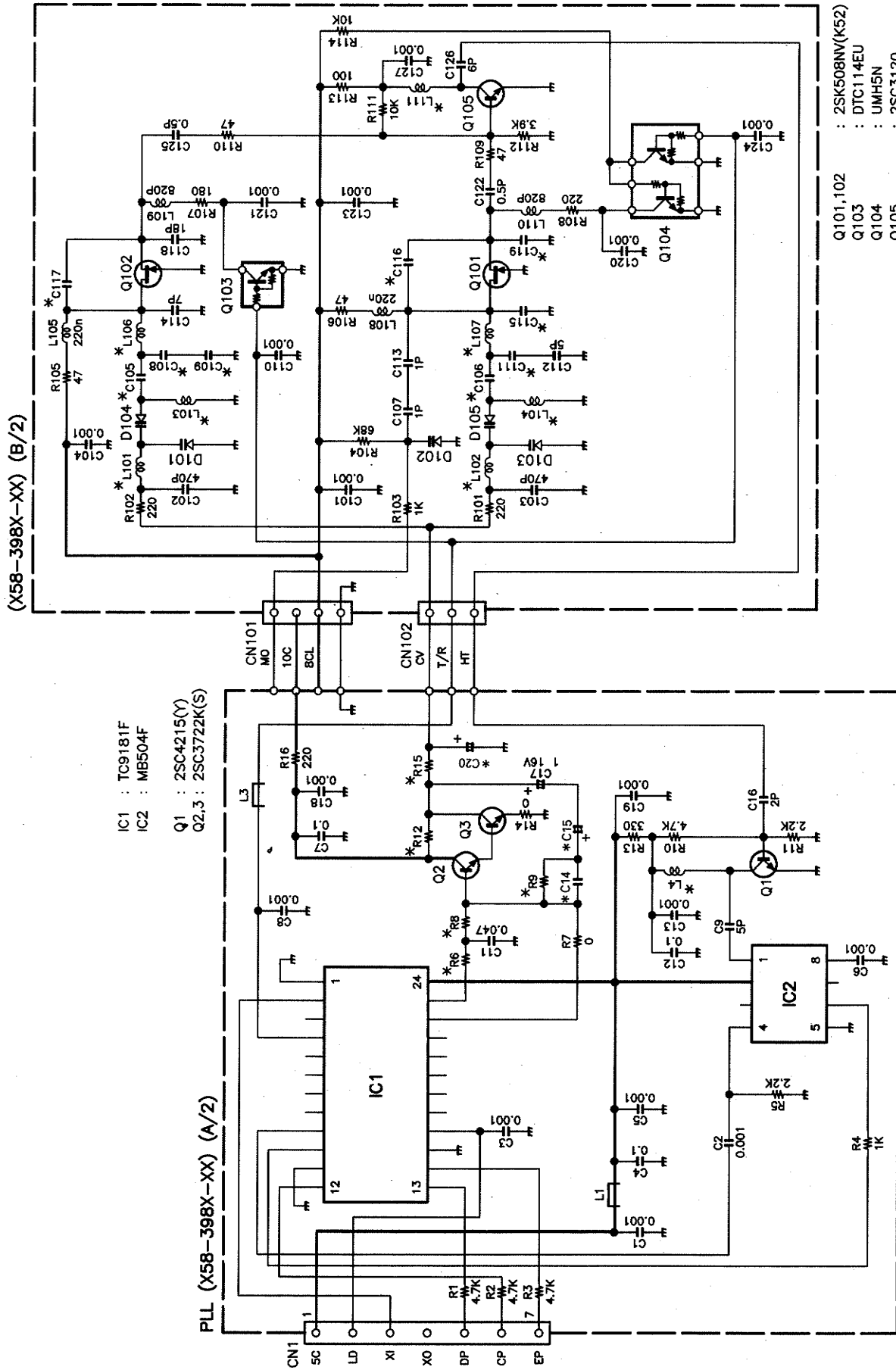

	C14	C15	C20	C105	C106	C108,109	C111	C115	C116	C117	C119	L4	L101,102	L103,104	L106	L107	L111	R6	R8	R9	R12	R15	
0-11	0.047	0.68	16V	0.068	35V	18P	9P	7P	5P	6P	15P	18P	100n	10u	2.2u	L34-4452	L34-4453	82n	1.5K	1K	3.9K	1.5K	3.3K
0-21	0.039	1.5	16V	0.047	35V	15P	12P	7P	5P	5P	12P	15P	82n	1.8u	1.8u	L34-4387	L34-4387	68n	0	2.7K	2.7K	1.5K	4.7K
2-71	0.039	1.5	16V	0.047	35V	8P	8P	6P	3P	6P	15P	18P	100n	10u	2.2u	L34-4452	L34-4453	82n	470	3.3K	3.3K	1K	3.9K

CIRCUIT DIAGRAMS / PC BOARD VIEWS TK-715/(N)

PLL (X58-398X-XX) (A/2) Component side view

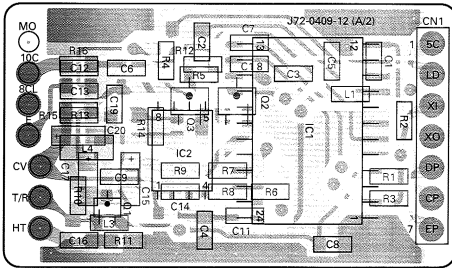

2SC3120
2SC3722K
2SC4215
DTC114EU



2SK508NV



UMH5N



PLL (X58-398X-XX) (A/2) Foil side view

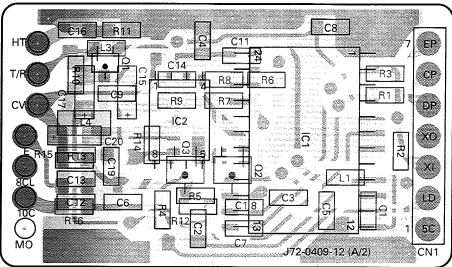

MB504F



TC9181F



PLL (X58-398X-XX) (B/2) Component side view

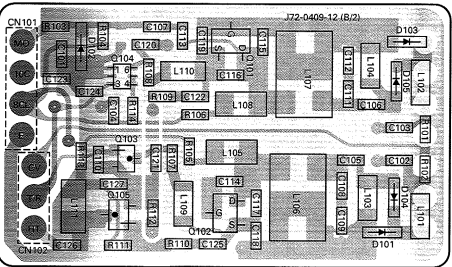

Component side
Foil side

45

APC (X59-4090-50)

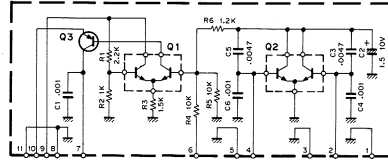

Q1, 2 : FMW1
Q3 : 2SA1162 (Y)

2SA1162
2SC2712



FMW1



APC (X59-4090-50) Foil side view

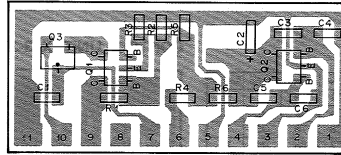

NJM4558M



HPF (X59-4100-XX) -50 : T,T3,X,E,E9,(N)M -52 : K

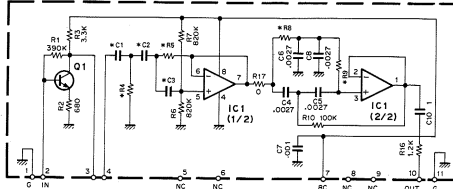

Q1 : 2SC2712 (Y)
IC1 : NJM4558M

	0-50	0-52
C1	2700P	0.022
C2	2700P	6800P
C3	2700P	0.012
C4	120K	-
R5	68K	12K
R8	120K	220K
R9	560K	470K

HPF (X59-4100-XX) Foil side view

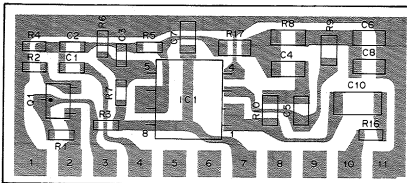

46

TK-715/(N) PC BOARD VIEWS

A B C D E F G H I J K L M N O P Q R S

2PD602A	HD63A03YRF	Ref. No. Address IC2 3M IC5 3K IC9 2P IC14 2I IC302 3N D2 3K D7 2J
1SS226	6264BLFP10LTZ	Component side Foil side
NJM78L05A	FX469LG	Pattern 1 Pattern 2 Pattern 3 Pattern 4
LM2924M 93LC46BT-1/SN	AT27C256R20JI	Ref. No. Address Ref. No. Address IC1 8N Q1 8P IC4 8L Q2 8J IC6 7S Q3 7P IC7 8S D1 7Q IC8 9P D3 6K IC11 7K D4 8G IC12 8K D5 7I IC13 8J D6 7H
HCF4016B		Component side Foil side
TC74HC00AF		Pattern 1 Pattern 2 Pattern 3 Pattern 4
HCF4099B		Ref. No. Address Ref. No. Address Ref. No. Address IC1 11N IC11 12K D1 12Q IC2 11M IC12 11K D2 11K IC4 11L IC13 11J D3 13K IC5 11K IC14 10I D4 11G IC6 12S IC302 11N D5 12I IC7 11S Q1 11P D6 12H IC8 11P Q2 10J D7 10J IC9 10P Q3 12P
TC74HC138AF		Component side Foil side

● Connect 1 and 4

CONTROL UNIT (X53-3792-70) : TK-715 (K,T,T3,X,E), TK-715(N) (M) (X53-3792-71) : TK-715 (E9) Component side view

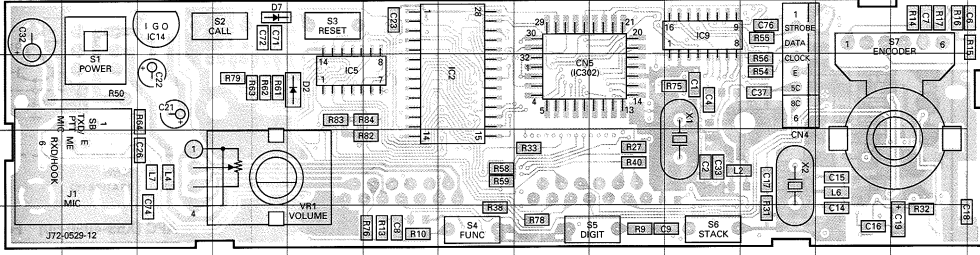

CONTROL UNIT (X53-3792-70) : TK-715 (K,T,T3,X,E), TK-715(N) (M) (X53-3792-71) : TK-715 (E9) Foil side view

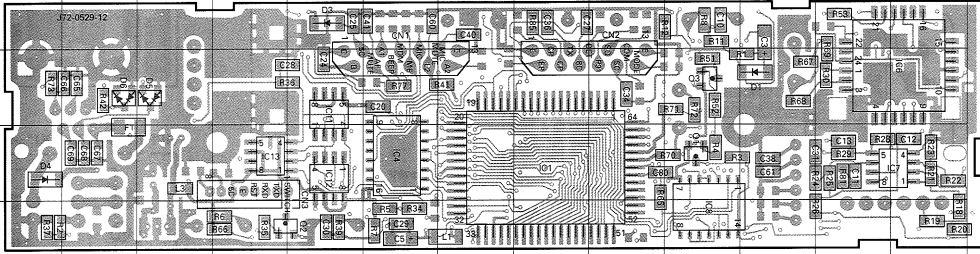

CONTROL UNIT (X53-3792-70) : TK-715 (K,T,T3,X,E), TK-715(N) (M) (X53-3792-71) : TK-715 (E9) Component side view + Foil side

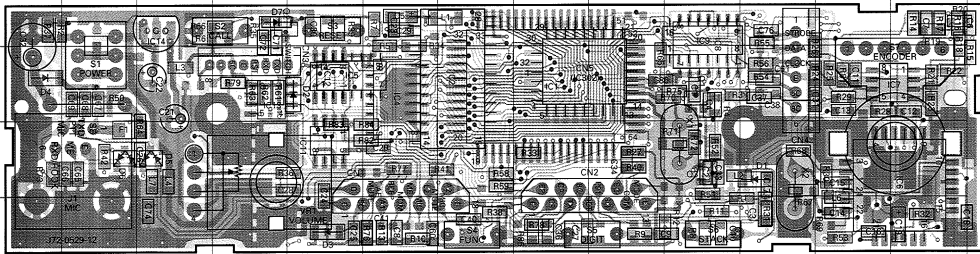

Note : We have been using the PC boards from serial No. 905XXXXX.

PC BOARD VIEWS (TK-715 : K,T,T3,X,E,E9) TK-715/(N)

TX-RX UNIT (X57-424X-XX) Component side view

0-11 : K 0-50 : T3 0-51 : T,X,E9 2-71 : E

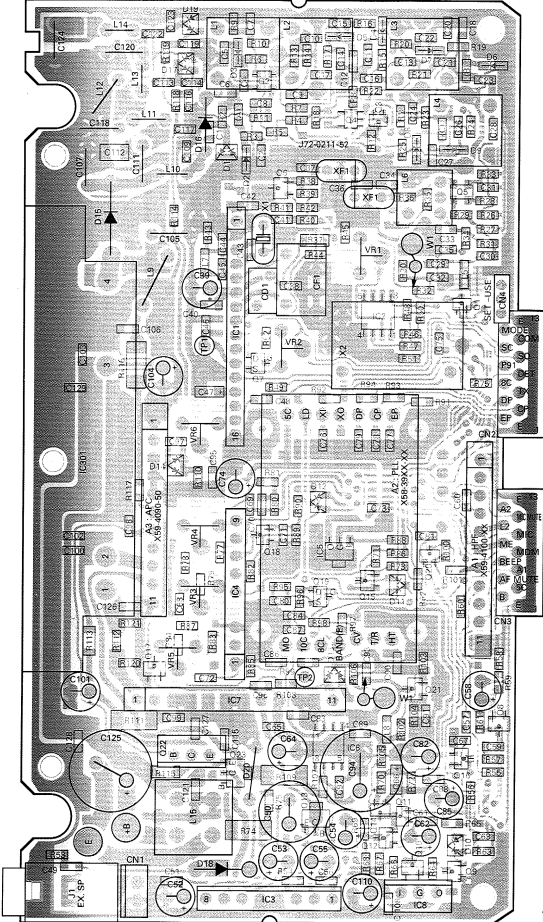

2SA1362 DTC114WK
2SC2714 DTC124TU
2SC4116 DTC144EK
DTC114EU DTC144WK

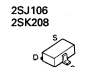
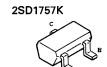
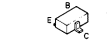

(A) C3 : T3
D21 : T,X,E9
Not use : K,E

(B) C19 : T3
D22 : T,X,E9
Not use : K,E

(C) C25 : T3
D23 : T,X,E9
Not use : K,E

Component side
Foil side

TX-RX UNIT (X57-424X-XX) Foil side view

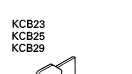
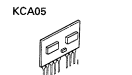
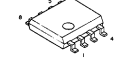
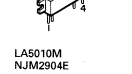
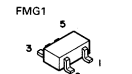
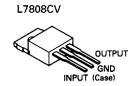
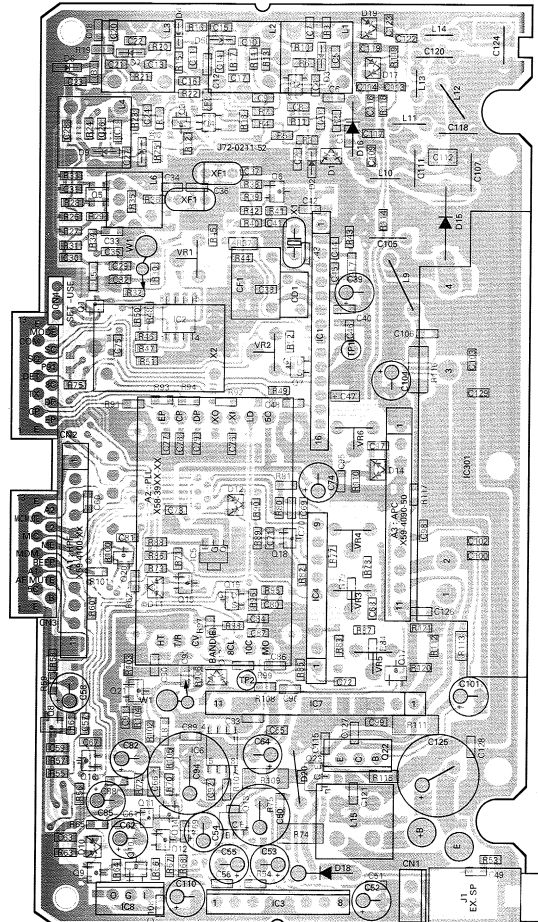

TK-715/(N) PC BOARD VIEWS (TK-715(N) : M)

TX-RX UNIT (X57-4250-21) : TK-715(N) (M) Component side view

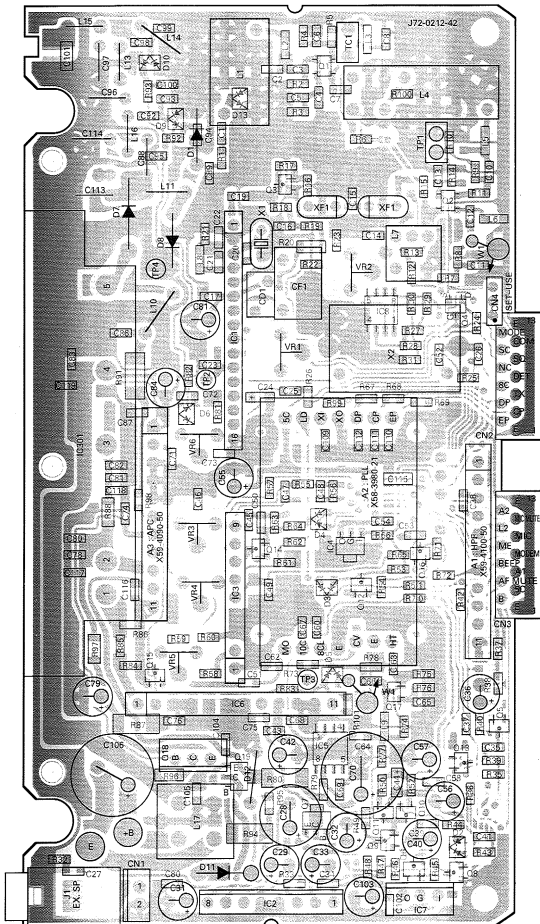

- 3SK184
- M68706
- LA5010M
NJM2904E
- UPC1241H
- KCA05
- KCB30
- KCD04

TX-RX UNIT (X57-4250-21) : TK-715(N) (M) Foil side view

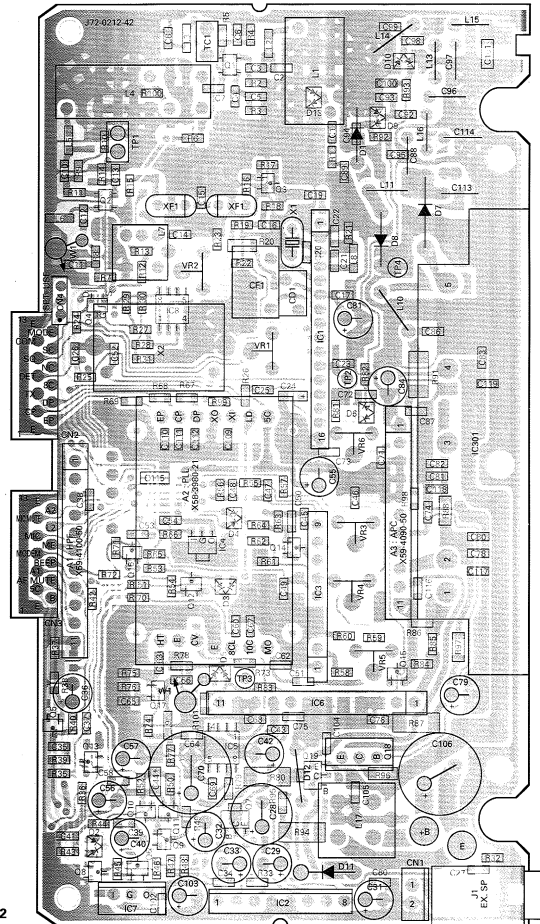

- 2SA1362
- 2SC2714
- 2SC2757
- 2SC4116
- DTC114WK
- DTC144EK
- DTC144WK

- 2SD1757K

- 2SB1119
- 2SB1302

- 2SD1406

- 2SJ106

- NJM78L05UA

- L7808CV



- Component side
- Foil side

TK-715/(N) CIRCUIt DIAGRAM (TK-715 : K,T,X,E,E9)

X57-424X-XX	A,B	A1	A2	IC7	IC301	Q5	X1	SP1	C6	C12	C18	C24	C28	C29	C34	C36	CR0,93	C106	C107	C109	C112	C118	C120	C124	C126	
D11 K	NO	X58-4100-02	X58-3880-11	KCB29	M5774E24	2SK1845	30.750MHz	30.3MHz	SP	10P	10P	10P	10P	NO	30P	10P	NO	300P	10P	3P	22P	10P	10P	10P	10P	10P
D11 T,X,E9	YES	X58-4100-01	X58-3880-01	KCB29	M5774E22	2SK131L	34.855MHz	34.4MHz	NO	3P	3P	10P	10P	YES	0.027	22P	10P	NO	10P	3P	22P	30P	30P	10P	NO	NO
2-71 E	NO	X58-4100-01	X58-3880-71	KCB29	M5774E24	2SK1845	30.755MHz	30.3MHz	4P	3P	3P	10P	3P	NO	0.027	10P	3P	22P	10P	3P	22P	10P	10P	10P	10P	10P

X57-424X-XX	L1-4	L5	L6	L30	L11	L13,14	R9	R37	R38	R39	R36	R54	R103	V96
D11 K	L34-4103-05	100Ω	L34-2187-05	L34-1207-05	L34-1208-05	L34-1127-05	0	20K	47	2.2K	470	100	20K	47K
0-61 T,X,E9	L34-4080-05	100Ω	L34-4191-05	L34-0895-05	L34-0742-05	L34-0489-05	10K	47K	10	4.7K	270	60	10K	20K
2-71 E	L34-4103-05	100Ω	L34-2187-05	L34-1207-05	L34-1208-05	L34-1127-05	0	20K	47	2.2K	470	60	10K	47K

TX-RX UNIT (X57-424X-XX) 0-11:K 0-51:T,X,E9 2-71:E

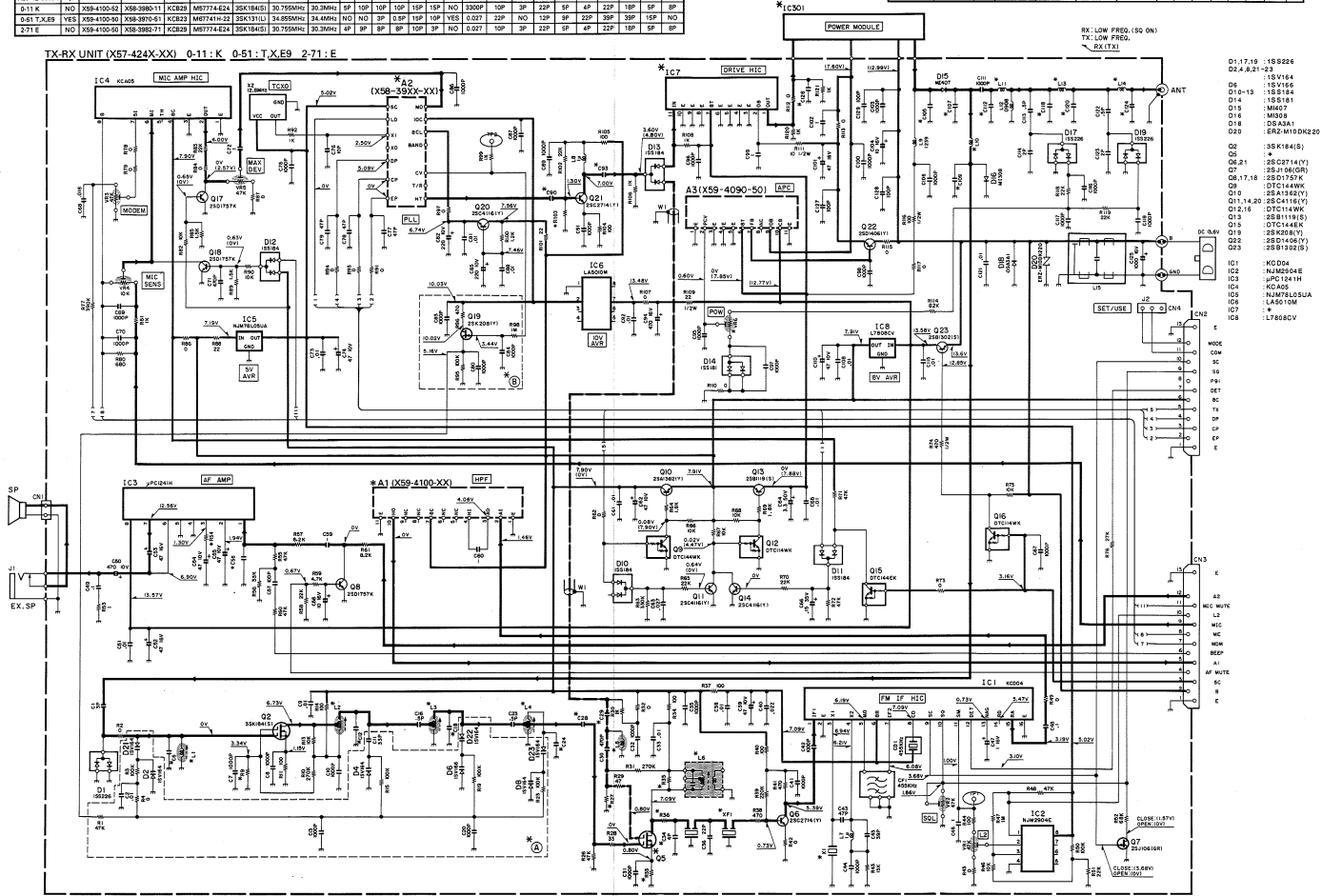

- D1-17:10 :18S226
- D2:4:8:21 :53
- D6 :15 V164
- D6 :15 V166
- D10-13 :18S164
- D14 :18S181
- D15 :M607
- D16 :M608
- D18 :DS4A1
- D20 :ER2-M10DK20
- Q2 :35 K144(S)
- Q7 :4
- Q8:21 :25 D3714(V)
- Q9 :25 J4(NGR)
- Q8:17:16 :25 D1737K
- Q9 :DTCT14WK
- D15 :25 A1482(V)
- Q11:14:20 :25C416(V)
- D12:16 :DTCT14WK
- D13 :25B1116(S)
- D15 :DTCT14WK
- D19 :25K289(V)
- D22 :25D1406(V)
- D23 :25B102(S)
- IC1 :KDD4
- IC2 :NM2504E
- IC3 :μPC1241H
- IC4 :K0A0
- IC5 :NMP70LS1A
- IC6 :LA5010M
- IC7 :4
- IC8 :L7808CV

CIRCUIT DIAGRAM (TK-715(N) : M) TK-715/(N)

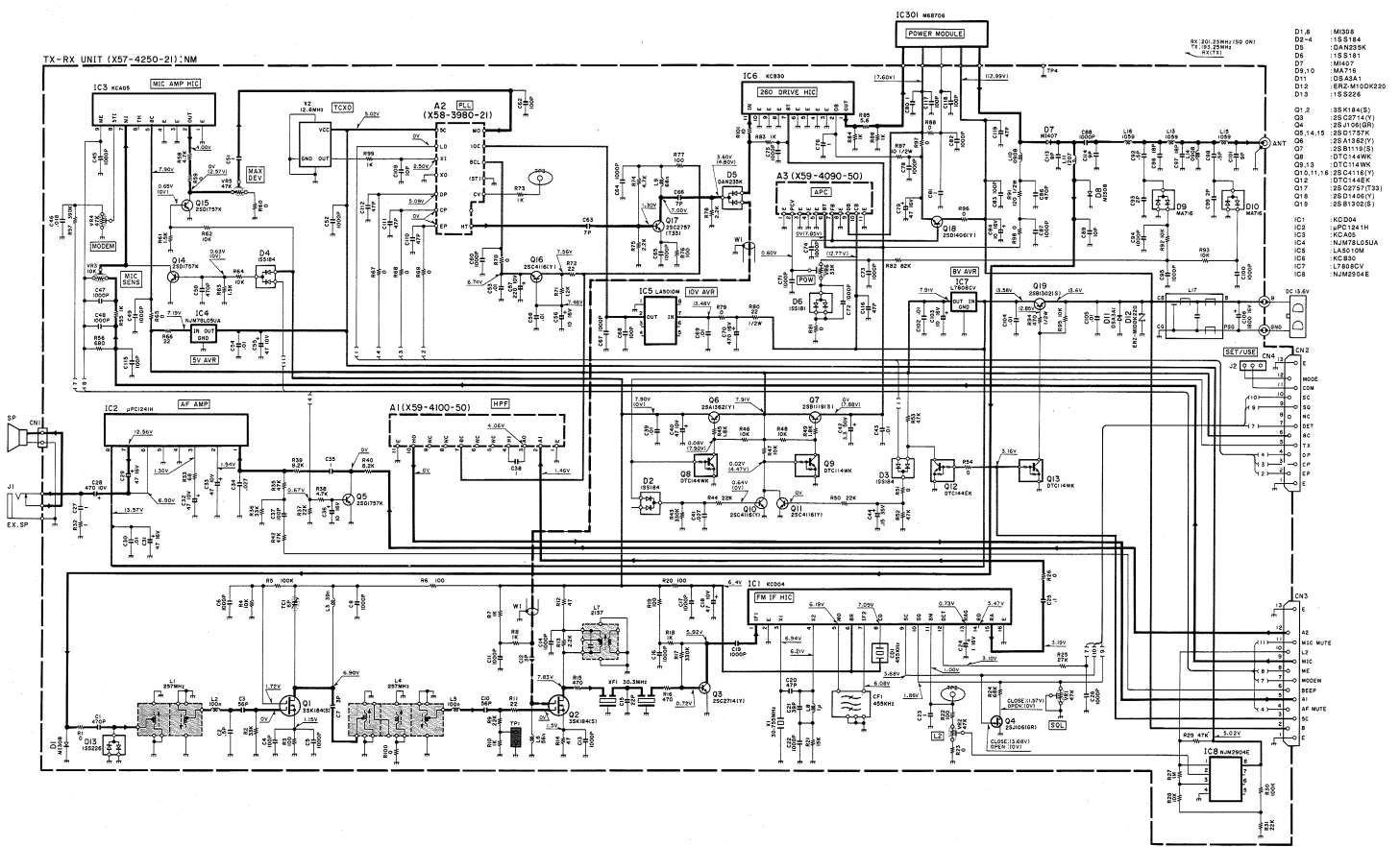

TK-715/(N) SCHEMATIC DIAGRAM

	C11	C17	R25	R81
-70	NO	0.1	47K	NO
-71	YES	3300P	220K	YES

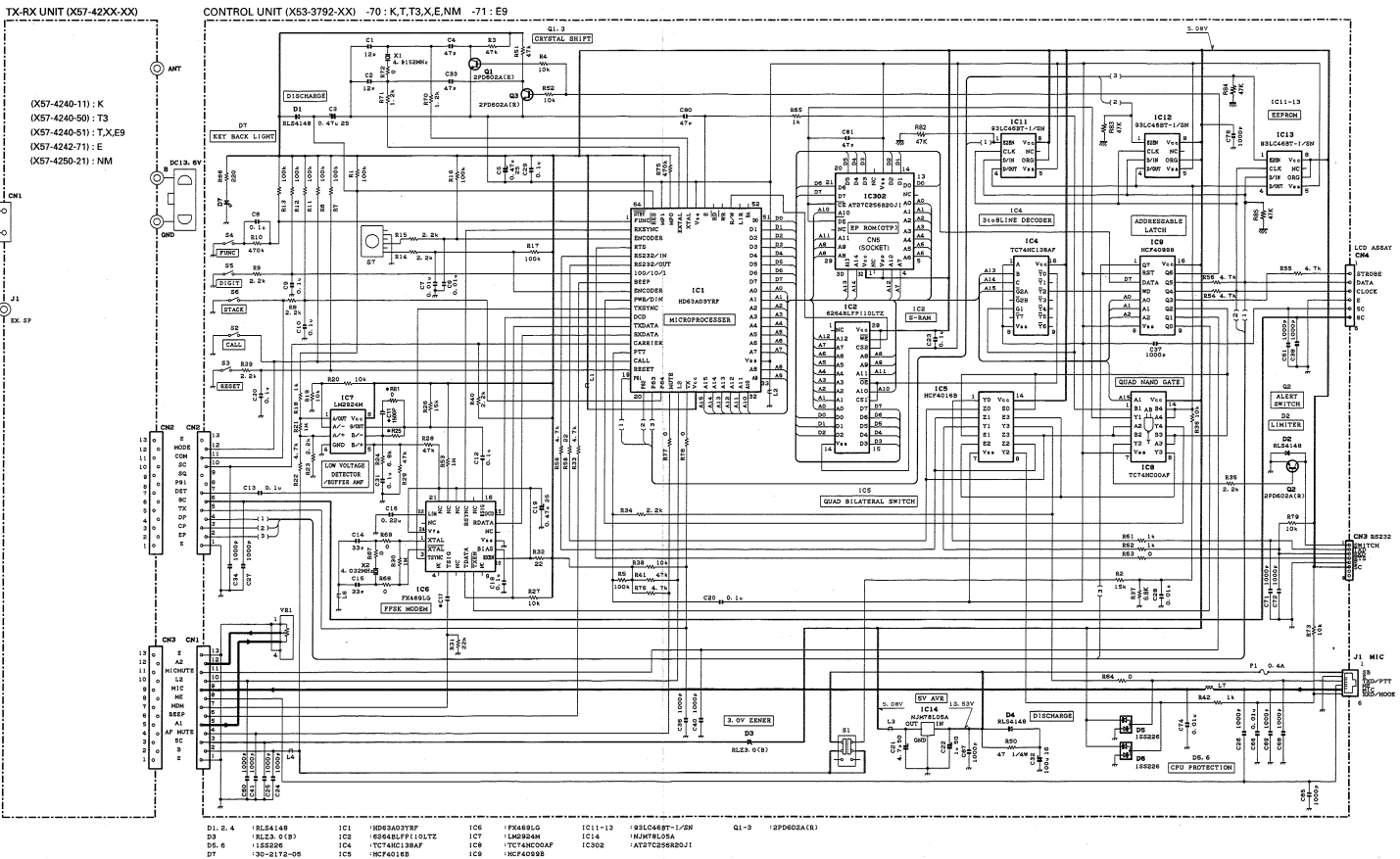

TERMINAL FUNCTION / KMC-9 (BASE MICROPHONE)

Connector No.	Terminal No.	Terminal Name	Terminal function
TX-RX UNIT (X57-42XX-XX)			
CN1	1	SP	Speaker input.
	2	E	GND.
CN2	1	E	GND.
	2	EP	PLL enable input.
	3	CP	PLL clock input.
	4	DP	PLL data input.
	5	TX	TX control input.
	6	8C	Common +8V output.
	7	DET	RX detection signal output.
	8	NC	Unused.
	9	SQ	Squelch adj. level setting output.
	10	SC	RA output mute control output.
	11	COM	
12	MODE		
13	E	GND.	
CN3	1	E	GND.
	2	B	+13.6V output.
	3	5C	+5V input. (Power switch control)

Connector No.	Terminal No.	Terminal Name	Terminal function
	4	AF MUTE	AF mute input.
	5	A1	AF signal output.
	6	BEEP	BEEP input.
	7	MODEM	Data modulation (FFSK).
	8	ME	MIC GND input.
	9	MIC	MIC signal input.
	10	L2	Acquisition threshold L2.
	11	MIC MUTE	MIC mute control input.
	12	A2	AF signal input.
	13	E	GND.
CONTROL UNIT (X53-3792-XX)			
CN1	= TX-RX UNIT CN3.		
CN2	= TX-RX UNIT CN2.		
CN3	For interface cable.		
CN4	For LCD ass'y.		
CN5	IC socket (IC302)		

KMC-9 External View



KMC-9 Parts List

Ref. No.	New parts	Parts No.	Description
1		E23-0612-08	Crimp terminal
2		E30-2080-08	Curl cord
3		G09-0423-08	L spring
4		G09-0424-08	R spring
5		G09-0425-08	Spring A
6		G13-0877-08	Cushion
7		G13-0878-08	Cushion D
8		J02-0448-08	Rubber foot
9		N44-3018-45	Tapping screw
10		N47-3010-46	Tapping screw
11		T91-0368-08	MIC unit
12		S50-1430-08	Micro switch
13		W02-0803-08	SW unit
14		W02-0395-08	MIC AMP unit

KMC-9 Specifications

Type	Uni-directional dynamic microphone (Preamplifier built-in)
Output impedance	600Ω ± 30% (at 1kHz)
Sensitivity	-50dB ± 3dB (at 1kHz, 0dB = 1V/μ bar)
Frequency characteristic	300 to 3000Hz (±6dB)
Power requirements	13.8V DC (Supplied from the radio)
Dimensions (W x H x D)	70 x 162 x 150 mm (2-3/4 x 6-3/8 x 5-29/32 inch)
Weight	550g (1.2 lbs)

KMC-9 (BASE MICROPHONE)

KMC-9 Disassembly for Repair

• Chassis removal

1. Remove the four rubber feet (❶).
2. Remove the four screws (❷).
3. Remove the chassis (❸).
4. Disconnect the 3-pin connector from the microphone amplification unit (❹).

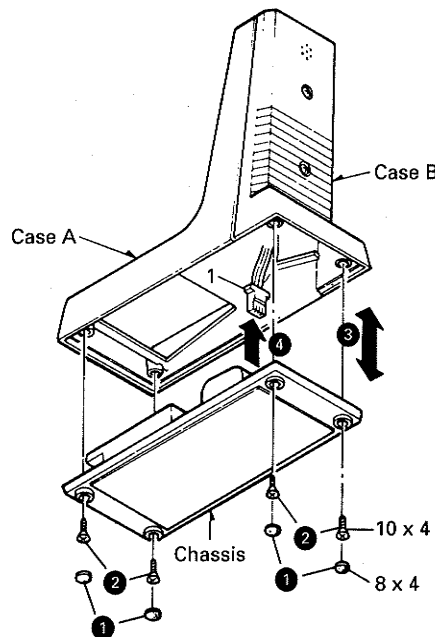

Fig. 1

• Removal of microphone element and microphone amplification unit

5. Remove the two screws holding cases A and B (❺).
6. Remove case B (❻).
7. Remove the microphone element and microphone amplification unit (❼).

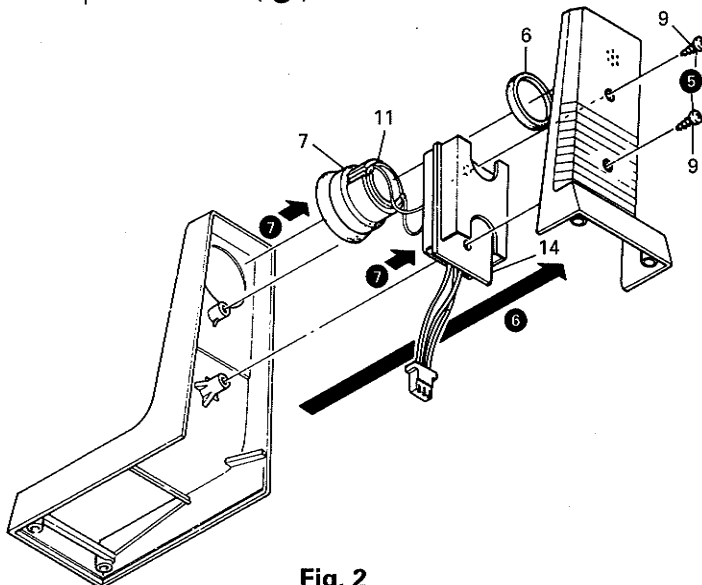

Fig. 2

• Switch unit removal

8. Disconnect the 6-pin connector (❸).
9. Remove the springs (L and R) (❹).
10. Pull out the shaft (❺).
11. Remove spring A and slider (❻).
12. Remove the switch unit while pressing the two claws holding the switch unit in the direction of the arrow (❼).

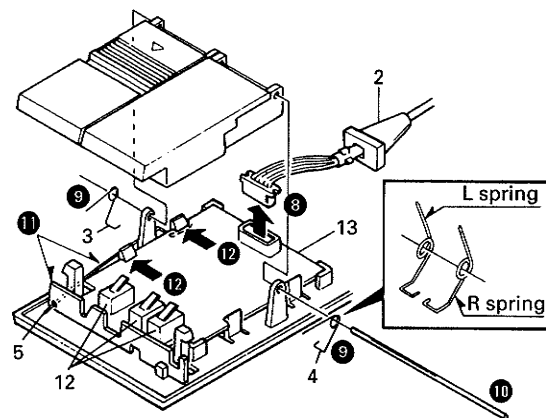

Fig. 3

• Removing microphone plug

To remove the microphone plug (module) from the Main unit or from the microphone, grasp the rubber cap from up and down with your fingers (to unlock it) and pull it out.

KMC-9 (BASE MICROPHONE) / KPG-19 (INTERFACE CABLE)

KMC-9 Circuit Diagram

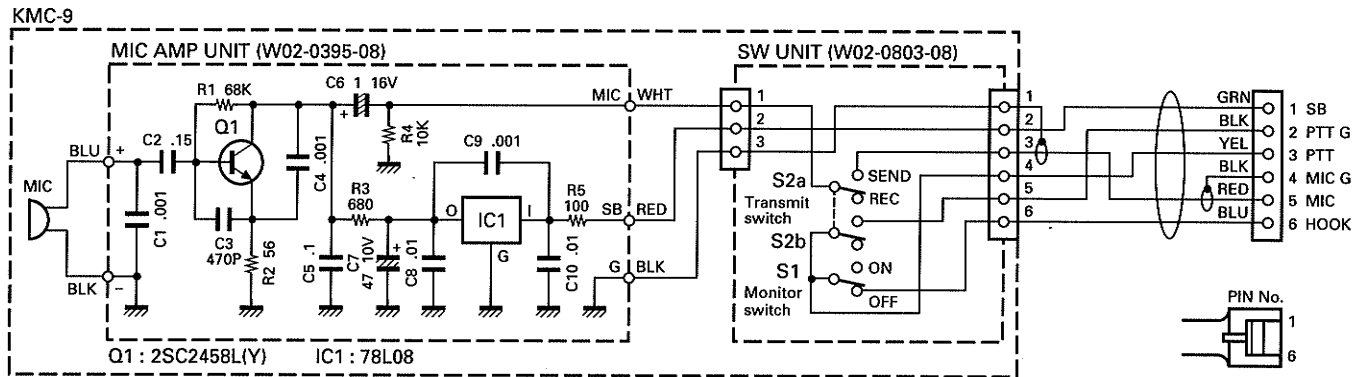

KPG-19 Circuit Diagram

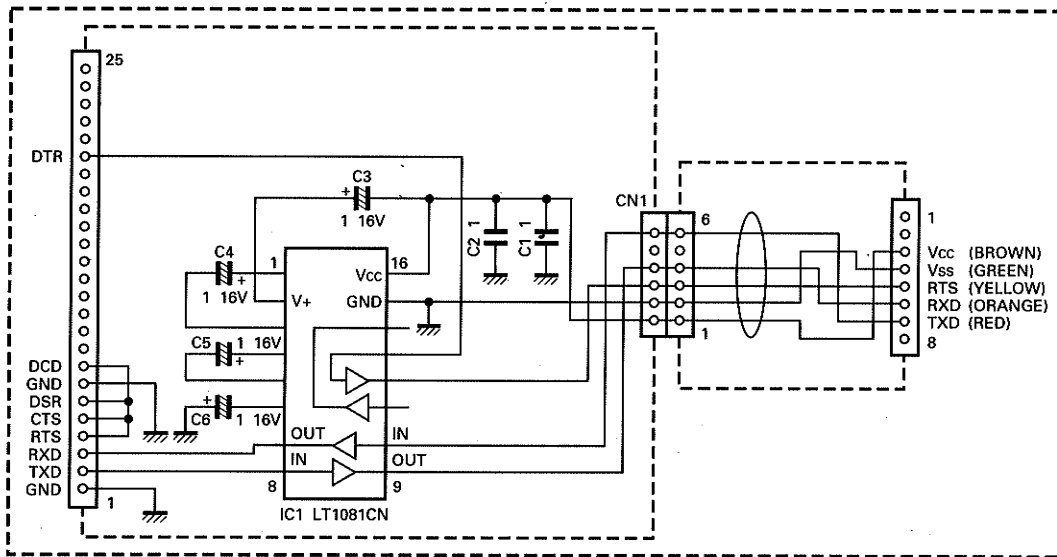

KPG-19 Parts List

Ref No.	New	Parts No.	Description
C1, 2		CK73EF1C105Z	Ceramic 1 μ F
C3~6		C92-004-05	Chip-tan 1 μ F 16WV
CN1		E37-0406-08	Connecting wire (6P-8P)
		E40-5171-05	Pin assy (6P)
		F07-1224-08	Cover
		H25-0728-04 H52-0457-04	Protection bag Item carton box
IC1		LT1081CN	IC

KENWOOD CORPORATION

14-6, Dogenzaka 1-chome, Shibuya-ku, Tokyo 150, Japan

KENWOOD SERVICE CORPORATION

P.O. BOX 22745, 2201 East Dominguez Street, Long Beach, CA 90801-5745, U.S.A.

KENWOOD ELECTRONICS LATIN AMERICA S.A.

P.O. BOX 55-2791 Piso 6 Plaza Chase Cl. 47 y Aquilino de la Guardia Panama, Republic of Panama

KENWOOD ELECTRONICS CANADA INC.

6070 Kestrel Road, Mississauga, Ontario, Canada L5T 1S8

KENWOOD ELECTRONICS DEUTSCHLAND GMBH

Rembrücker Str. 15, 63150 Heusenstamm, Germany

KENWOOD ELECTRONICS BELGIUM N.V.

Mechelsesteenweg 418 B-1930 Zaventem, Belgium

KENWOOD ELECTRONICS FRANCE S.A.

13, Boulevard Ney, 75018 Paris, France

KENWOOD ELECTRONICS U.K. LIMITED

KENWOOD House, Dwight Road, Watford, Herts., WD1 8EB United Kingdom

KENWOOD ELECTRONICS EUROPE B.V.

Amsterdamseweg 37, 1422 AC Uithoorn, The Netherlands

KENWOOD ELECTRONICS ITALIA S.p.A.

Via G. Sirtori, 7/9 20129 Milano, Italy

KENWOOD IBERICA S.A.

Bolivia, 239-08020 Barcelona, Spain

KENWOOD ELECTRONICS AUSTRALIA PTY. LTD.

(A.C.N. 001 499 074)

P.O. Box 504, 8 Figtree Drive, Australia Centre, Homebush, N.S.W. 2140, Australia

KENWOOD & LEE ELECTRONICS, LTD.

Unit 3712-3724, Level 37, Tower one Metroplaza, 223 Hing Fong Road, Kwai Fong, N.T., Hong Kong